

SPIKE BED

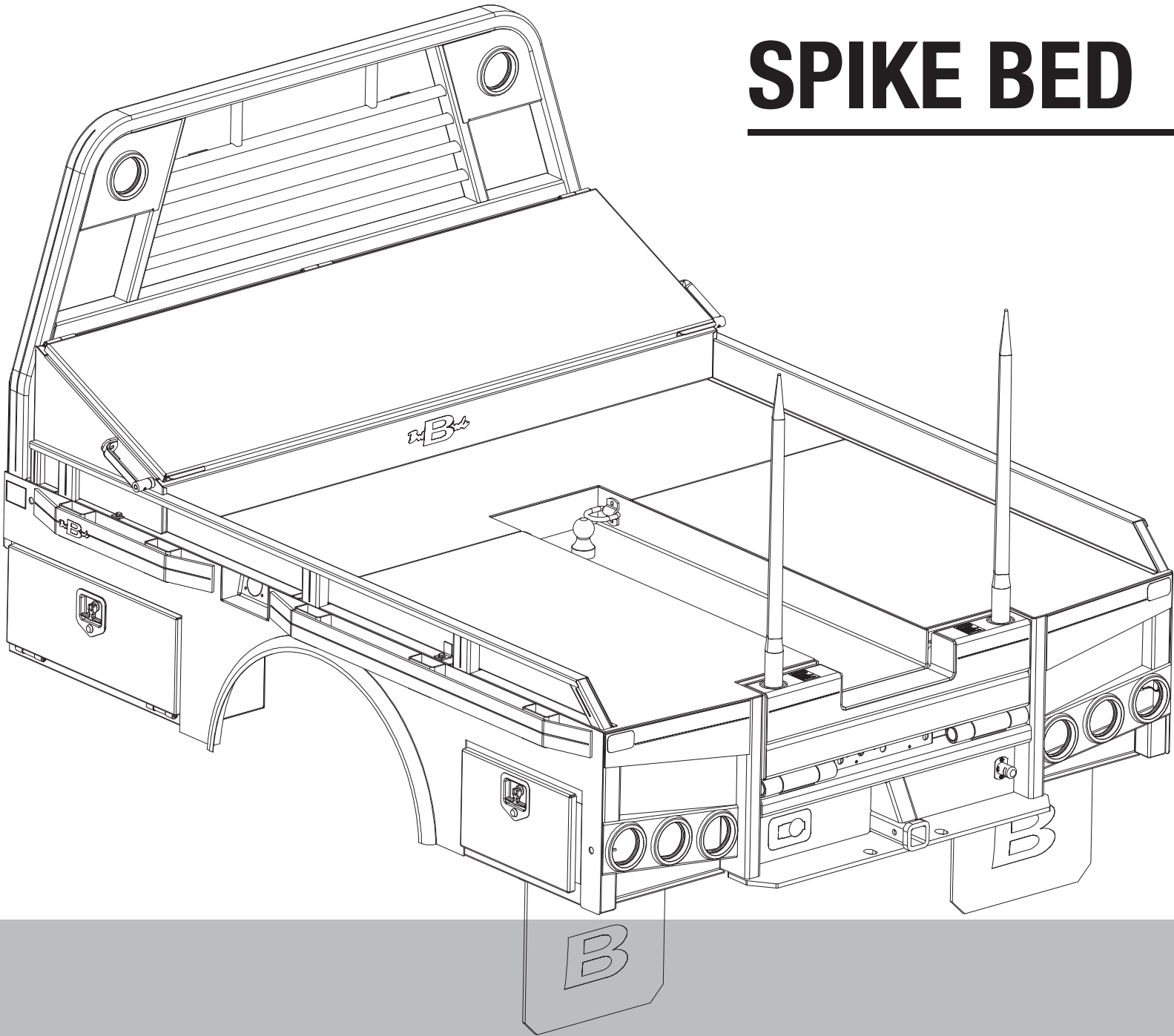

Butler Beds

Thank you for purchasing a Butler Spike Bed.

TO THE OWNER OR OPERATOR:

As with all Harper products, the Butler Beds have been thoroughly tested and built to provide a sturdy, dependable product. The Spike Bed is equipped with live hydraulics, which allows it to be used for a wide range of lifting and hauling tasks. This manual is written as an aid to operating and maintaining the Butler Spike Bed. Read and understand the manual thoroughly before operation to avoid damage to the unit or injury to the operator or bystanders.

A Spike Bed can present hazards to an operator who follows unsafe procedures in either the operation or maintenance of the unit. Therefore, **SAFETY WARNINGS** are present at certain locations in the text. Harper Industries is not responsible for accidents or injuries that result from the misuse or lack of maintenance of the Flatbed.

SYMBOL:



SAFETY WARNING!



MEANING: Failure to understand and obey this warning may result in injury to you or others. Whenever this symbol is used, please pay very close attention to the information presented, and make sure you fully understand. If you do not, contact your dealer or Harper Industries for clarification.

///HARPER[®]INDUSTRIES, INC.

151 E. HWY. 160 Harper, KS 67058
(620) 896-7381 • **Fax** (620) 896-7129

Toll Free 800-596-2464

Email info@butlerbeds.com

Website www.butlerbeds.com

© 2026 Harper Industries, Inc.

The Butler logo are registered trademarks of Harper Industries, Inc. All other brand and product names are trademarks or registered trademarks of their respective companies.

Statement of Warranty 1/11/2025

Harper Industries, Inc. (HII) warrants to each purchaser of a new Butler Bed from an authorized dealer or representative, that such equipment is free of manufacturer's defects in workmanship and materials which appear while in normal service for a period of ONE YEAR commencing with delivery to the original user.

The obligation of HII under this warranty is expressly limited, at our option, to replacement or repair at a service facility designated by Harper Industries or at the manufacturing plant in Harper, KS. A part will be replaced after inspection discloses it to have been defective. This warranty does not apply to defects caused by damage or unreasonable use (including failure to provide reasonable and necessary maintenance, or by performing functions without genuine Butler Bed accessories) while in the possession of the consumer.

Warranty is limited to parts, labor and ground freight delivery of replacement parts. HII shall not be liable for the consequential damages of any kind, including but not limited to consequential labor costs or transportation charges in connection with replacement or repair of defective parts.

This warranty does not apply to parts subjected to misuse, abuse, alteration, improper or inadequate maintenance, or normal wear.

Harper Industries makes no warranty with respect to trade accessories. They are subject to the warranties of their respective manufacturers (including belts, battery, chains, filters).

ANY IMPLIED OR STATUTORY WARRANTIES, INCLUDING ANY WARRANTY OR MERCHANTABILITY OR FITNESS FOR A PARTICULAR PURPOSE, ARE EXPRESSLY LIMITED TO THE DURATION OF THIS WRITTEN WARRANTY. HII makes no other express warranty, nor is anyone authorized to make any on behalf of HII.

For further information please contact your nearest Butler Bed dealer.

RECORDS

Date of Purchase _____ / _____ / _____

Dealer's Name _____

Dealer's Phone _____

Serial Number Bed _____

Serial Number Pump _____

**SCAN
& REGISTER**

- Scan the QR code with your smart phone
- Register the details of your new Butler Spike Bed
- We'll send you a new hat to welcome you to the Butler family



SCAN FOR YOUR FREE BUTLER HAT!
(Remove sticker after registering)

Table of Contents

OPERATOR SECTION

To the Owner or Operator.....	1
Warranty Statement.....	2
Table of Contents.....	3
Specifications.....	4
Feature Identification.....	5
Safety Guidelines	
General Equipment Safety.....	6
Spike Bed Operation Safety.....	6
Hydraulic Safety Warning.....	6
Operating Instructions	
Loading Instructions.....	6
Unloading Instructions.....	6
Spikes.....	7
Maintenance	
Check Daily or Before Use.....	7
Lubrication.....	7
Toolbox Mounting.....	7
Hydraulics.....	7
Fuse & Fuse Holder.....	8
E/H Power Unit Identification.....	8
Pairing (Synchronizing) the Wireless Lodar.....	8
Installing Corded & Wireless Controls.....	9
Troubleshooting.....	10
Amp Draw Chart.....	11

PARTS SECTION

Side Rails.....	14
Spikes & Pivot Gates.....	15
Spike Fork Assembly.....	16
Lift Cylinders.....	17
Hoses: Standard, Trough and Coupled.....	18-19
Bed Service Parts.....	20
Decals.....	21
Completing Kit (E/H, Controls & Hardware)..	22
Controls: Corded & Wireless.....	23
E/H Power Unit.....	24
E/H Schematic.....	25
Lights & Mounts.....	26
Electrical Harnesses.....	27-28
Harnesses: OEM to Butler Adapters.....	29-30
Toolboxes.....	31
Mudflaps.....	32
Bed Mounting Kits.....	33
Rear View Camera Mounts.....	33
Bed Lengths for Cake Feeders.....	34

Specifications

Butler Spike Beds are specifically designed to transport and feed round hay bales.

Model Specifications

MODEL	80X86	80X102	80X110	80X115	84X86	84X102	84X110	84X115	94X102	94X110
WIDTH	6'8"	6'8"	6'8"	6'8"	7'0"	7'0"	7'0"	7'0"	7'10"	7'10"
LENGTH	7'2"	8'6"	9'2"	9'7"	7'2"	8'6"	9'2"	9'7"	8'6"	9'2"

MODEL	94X115	94X134	94X139	96X86	96X102	96X110	96X11	96X134	96X139	
WIDTH	7'10"	7'10"	7'10"	8'0"	8'0"	8'0"	8'0"	8'0"	8'0"	
LENGTH	9'7"	11'2"	11'7"	7'2"	8'6"	9'2"	9'7"	11'2"	11'7"	

Hydraulic System Specifications

HYDRAULIC SYSTEM	Electric over hydraulic
SYSTEM PRESSURE	2500 psi
FLOW	2.41 gpm @ 500 psi: 1.06 gpm @ 2500 psi
OIL RESERVOIR CAPACITY	10 quarts ATF fluid (Dextron III)
CYLINDER, LIFT	1.25" X 3.5" X 12"
LIFT CAPACITY (centered)	2,500 lbs.

Protective Coating Specifications

PAINT	Heat-cured, polyurethane based paint
-------	--------------------------------------

Bed Weights

ARM	84x84	84x101	84x108	84x113	94x101	94x108	94x113	94x132	94x137		
WEIGHT	1448	1502	1528	1886	1845	1950	1975	?	2152		
SKIRTED	1687	1962	?	?	?	?	?	?	?		

SPIKE	80x84	84x84	84x102	84x110	84x115	94x102	94x110	94x115	94x134	94x139	
WEIGHT	1283	1350	1400	1500	1544	1184	1614	1622	?	?	
SKIRTED		1199	1467	?	?	1709	?	?	?	?	

FLATBED	80x102	84x84	84x102	84x110	84x115	90x115	94x102	94x110	94x115	94x134	94x139
WEIGHT	1225	1133	1180	?	?	1309	1169	?	1334	?	1497
SKIRTED		1302	1470	?	?		1255	?	?	?	?

Feature Identification

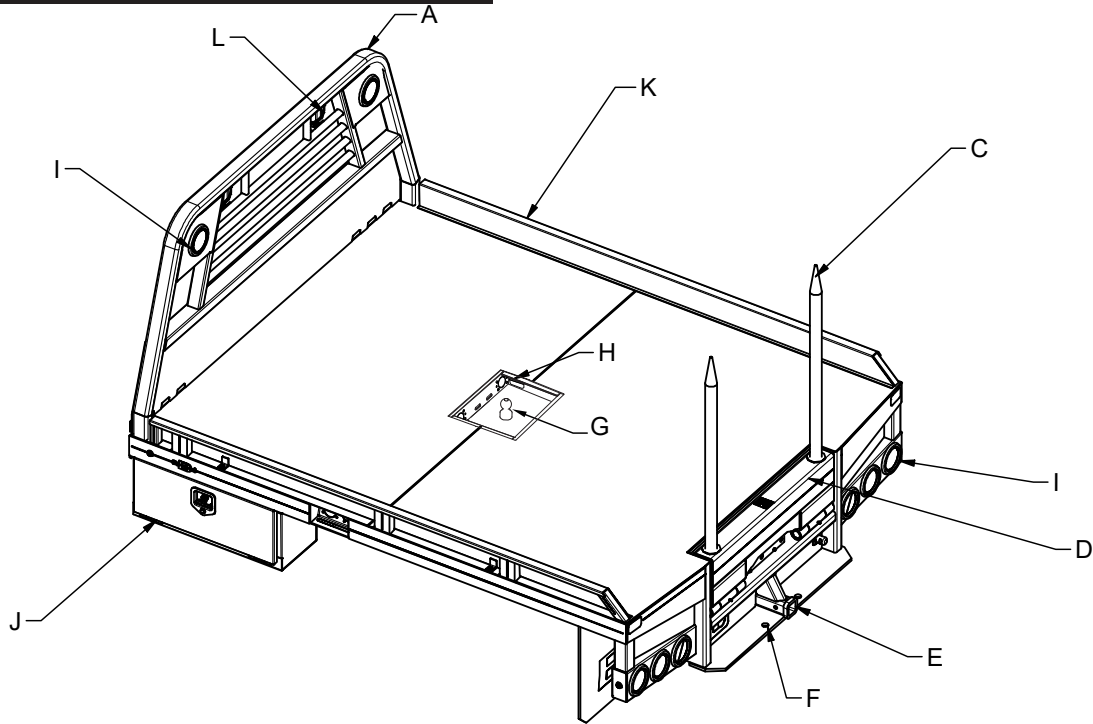

A. Headache Rack – protects the rear pickup window.

B. Across-the-bed Toolbox (not pictured) – mounted across the front of the bed.

C. Spikes – used to stick and lift bales.

D. Pivot or Tailgate – houses the spikes and pivots to lift the bale.

E. Hitch Plate – allows for a 2” square receiver (Class IV) hitch and has holes for hitch pins.

F. Safety Chain Loops – always use safety chains when towing.

G. Gooseneck Hitch – located under a cover plate in the middle of the bed or as a pop up ball.

H. Safety Chain Loops – always use safety chains when towing.

I. Lights – LED lighting for stop-tail-turn. (Optional lights in headache rack)

J. Toolboxes – mount under front of bed on both sides. The Electric/Hydraulic Power unit mounts inside the passenger side toolbox.

K. Side rails or Dummy Arms – serve as side rail.

L. Work Lights (optional) – lights can be when working at night.



SAFETY WARNING!
Do not stand near tailgate when operating the bale pickup, even when unit is empty.

Safety Guidelines

Operator safety is of upmost concern when designing and developing a new piece of equipment. Designers and manufacturers build in as many safety features as possible. However, every year many accidents occur which could have been avoided by a few seconds of thought and a more careful approach to handling equipment. Most accidents can be avoided by observing the precautions in this section. To avoid personal injury, study the safety warnings and cautions listed in this manual and follow them.

General Equipment Safety

- This equipment can be dangerous to children and persons unfamiliar with its operation. The operator should be a responsible adult familiar with farm machinery and trained for this unit.
- Do not attempt to operate equipment under the influence of drugs or alcohol.
- Do not allow persons to operate or assemble this unit until they have read this manual and have developed a thorough understanding of the safety precautions and how the unit works.
- Review the safety warnings and cautions with all users annually.

Spike Bed Operation Safety

- Replace any CAUTION, WARNING, DANGER, or instruction decal that is not readable or is missing.
- Make sure all safety pins are in place and flatbed mounting bolts are secure to the truck frame.
- Make sure hinges, joints, and sliding parts are well greased, especially during off season to prevent rusting and binding.
- Check with truck dealer for any load limits, additional suspension, or tire requirements. The Spike bed's lifting capability may exceed the truck's load capacity in some instances.

Hydraulic Safety



SAFETY WARNING!



Hydraulic system operates under high pressure and escaping fluid can penetrate the skin.

Operating Instructions

Loading Instructions

- Center spikes as close as possible to the center of the bale.
- Back the truck up to the bale with the spikes down, pushing the spikes into the bale.
- Lift the bale by pushing the UP button on the controller until the bale is lifted as high as possible (verticle spikes).
Do not haul spiked bales with spikes beyond 90°.



CAUTION



Do not exceed the GVRW of the truck.
Unloading Instructions.

NOTE: When hauling multiple bales short distances, motor will become hot. Allow motor to cool down in between loading cycles. General rule of thumb is 25% motor on, 75% motor off. This equals about 2 ½ minutes "motor on" in a 10 minute period. Opening the tool box lid may help with the cool down.

Unloading Instructions

- Lower the bale to the ground by pushing the DOWN button on the controller.
- Drive the truck forward.
- Once the spikes are clear of the bale, push the UP button to raise spikes to return to the home position.

Spikes

- Remove the spikes at least once a month. The spikes seat into the pivot very tightly. **Failure to remove the spikes monthly could cause them to seize up and become difficult to remove.**

Maintenance

Check Daily or Before Use

- Check the hydraulic oil level. Keep the level to "FULL" on the dipstick.
- Examine the hydraulic hoses for leaks with an object such as cardboard.



SAFETY WARNING!



Hydraulic fluid escaping under pressure can penetrate the skin and may cause death if not treated immediately.

Lubrication

- Put rear pivot all the way in the down position.
- Locate the two pivot pins, and grease them both (2).



SAFETY WARNING!



Use extreme caution when greasing the flatbed. Completely lower pivot tailgate to expose rear zerks and turn off ignition.

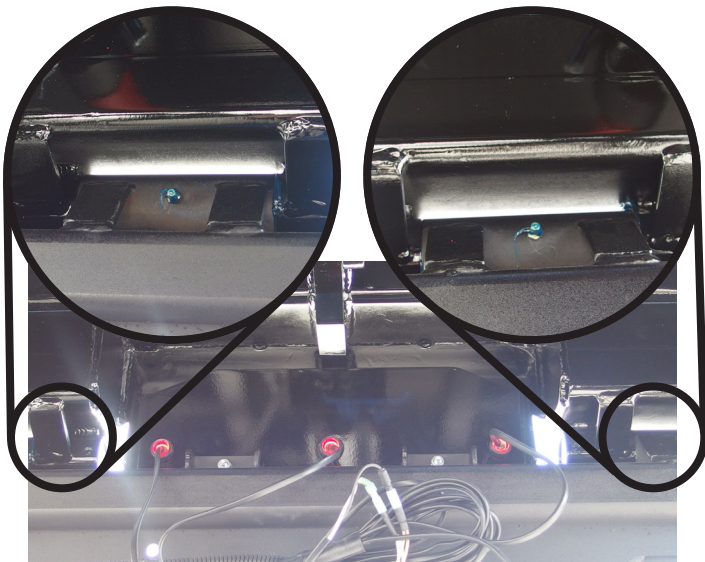

Toolbox Mounting

- Mount the box with the two bolt holes on the short end towards the front. Bolt the top of box to the welded bracket under the bed. All bolts are 3/8".

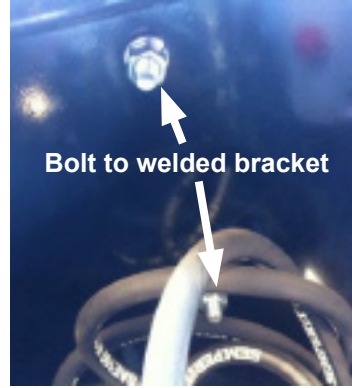

Hydraulics

Hydraulic System

- High heat, 190° or greater, can be damaging to the hydraulic system. Check various parts of the system to make sure there are no "hot spots" which may indicate a problem.
- In the off season, run the bed at least twice a month to prevent valve condensation.

Hydraulic Hose Connections

- Connect 1/4" taped hose (rod) to C1.
- Connect 1/4" hose (base) to C2.

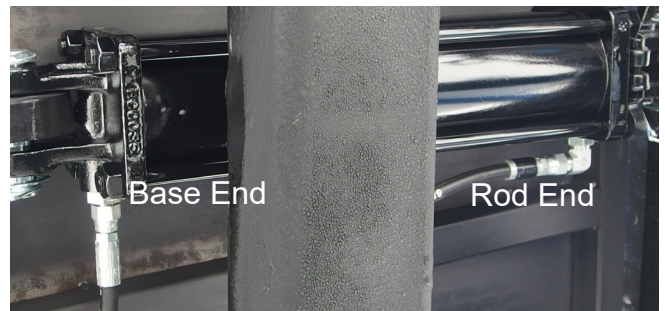

Fuse & Fuse Holder

The 250 amp (Arm Bed) or the 200 amp (Spike Bed) fuse and holder attach to the battery's positive post.

Attach positive cable here

Part numbers
on page 22

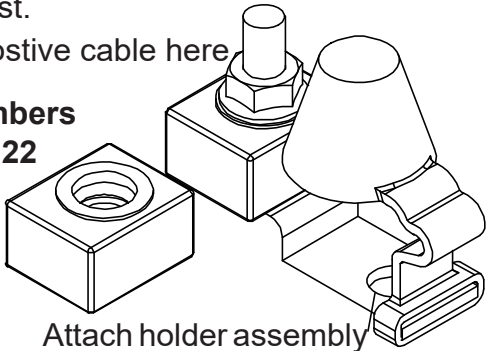

Attach holder assembly
to positive battery post



Mounting of Power Unit

Place power unit in passenger side box with the reservoir facing the cab of the truck. Position the holes in bottom of pump block over holes in bottom of box. Using 3/8" bolts, secure the pump to the box. Run the hydraulic hoses through the rubber grommet in the box. The power unit operates best with a two battery set up. If needed, the second battery can be mounted next to the power unit in the tool box.

LODAR: BUTLER SPIKE BED

*Receiver NOT SOLD separately. Must buy kit.
Transmitter can be purchased individually.

ITEM	QTY	PART #	DESCRIPTION
1	1	233009	*RECEIVER/TRANSMITTER
2	1	232165	Transmitter
3	1	233014	Receiver/Transmitter Assy (new installs)

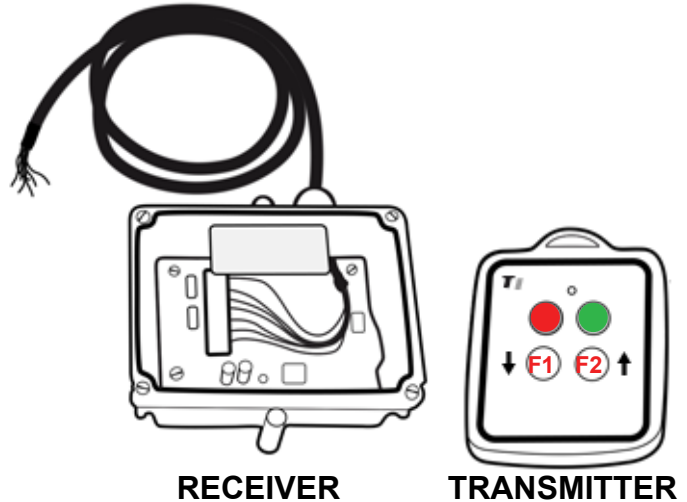

Pairing (Synching) the Wireless System

1. NO POWER - **receiver**
2. PRESS RED & GREEN *transmitter* buttons until its LED turns off. Release the buttons (it will blink "search" afterwards)
3. POWER - **receiver**
4. HOLD *transmitter* GREEN button until the **receiver** GREEN LED is solid. Release button.
5. Hold the RED button to turn the *transmitter* off. When you turn the *transmitter* back on, it will be synched.

Power Unit Identification

Bale Down (Unload) Check Valve

Motor Start Solenoid

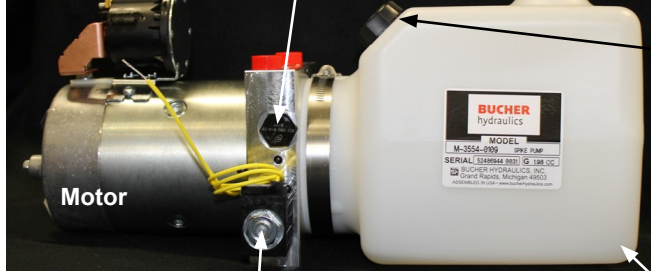

Bale Coil (black box)
& Cartridge Valve Stem

Reservoir

Bale Up (Load) Check Valve

Manifold Plug

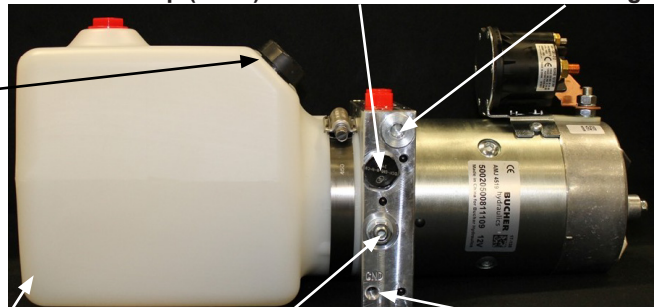

Pressure Relief Valve

Ground

BUTLER SPIKE CORDED & WIRELESS: BUCHER VALVE

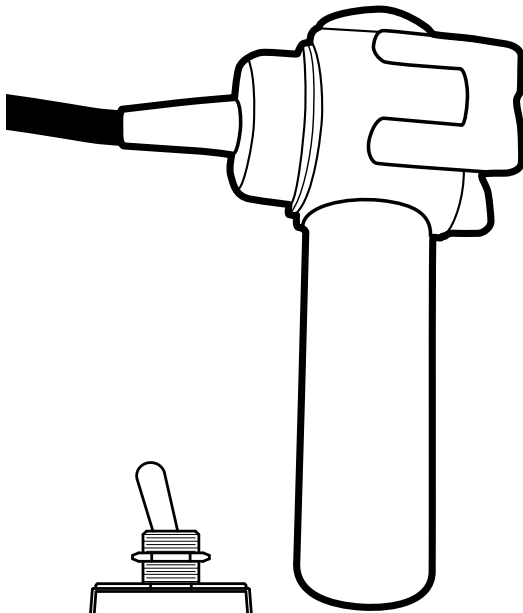

Parts List			
ITEM	QTY	PART #	DESCRIPTION
1	1	232151	Wired, Hand Control One Switch
2	2	232172	Switch, SB Hand Control

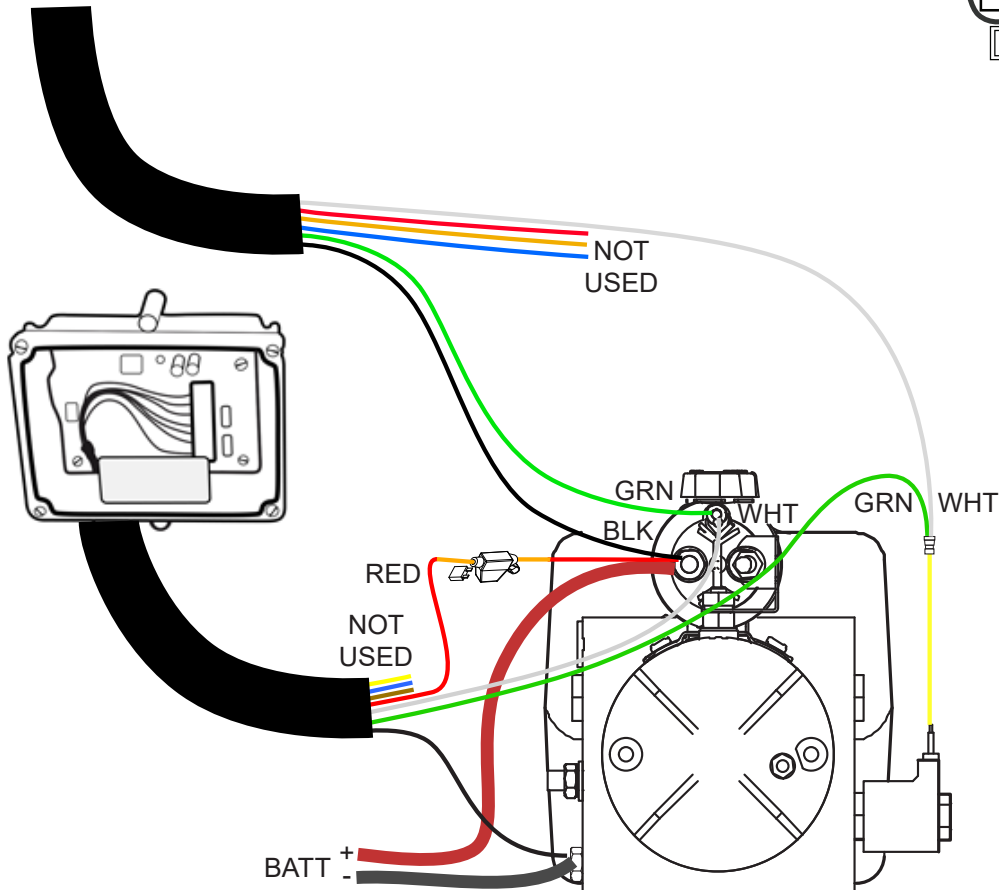
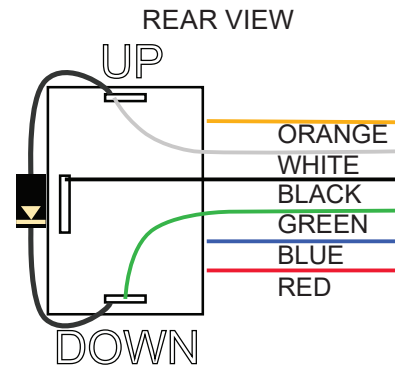
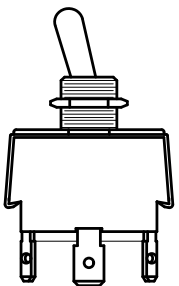

Troubleshooting

The most common problems with a power unit are due to low voltage from a battery, fuse failure, faulty wire or a failing ground connection. To narrow down the problem, connect jumper cables to the pump (positive to input side of solenoid & negative to the ground on pump base). Use a separate good battery (from another vehicle or a new battery). If the pump and bed operate properly, then have the battery tested, check in line fuse and power cord, and/or run ground cable directly to the battery instead of inside the tool box or frame. If the pump does not operate properly with jumper cables, then check solenoid and/or motor.

PROBLEM	SOLUTION
Power unit not responding to remote when toggle is activated	Use test light on remote connections to solenoid. If any connections are not working, the problem is in the remote. If all connections are working, check solenoid. If solenoid is working properly, the problem is in the pump motor.
Motor is humming or bed is operating slowly	Pump motor is failing.
Bale drops on its own when suspended in the air or will not maintain a tight squeeze	Turn the counter-balance valve $\frac{1}{4}$ turn clockwise until bale suspends normally. Do not tighten screw all the way in.
Spike pivot are not moving fast / pressurizing but not moving	Check for debris in the check valve. Make sure spring plunger is not broken.
Lift is not working	Check wire on cartridge valve coil for a short or take coil off and activate remote while putting a screwdriver inside coil. If screwdriver does not magnetize to coil, the coil is failing. If coil is magnetizing, then failure is in cartridge valve.
Fluid leaking under bed or in tool box	Check hose connection at leak. Tighten or replace if needed. Leaks in tool box are best diagnosed by activating the remote while watching the power unit. Determine where the leak is coming from and replace O-ring / plug / valve if needed. Some leaks are fixed by tightening the plug/valve. Make sure the plastic reservoir is not cracked.

How to Check

Solenoid	Check the two posts. If posts show voltage, then the solenoid is good.
Pump	Make sure there is good voltage to the motor. If motor checks out good check for broken or worn gear. If there is a grinding or metallic noise, the pump needs to be replaced.
Motor	Check amp range using chart below. Arm & spike beds draw different amps at different pressures.

AMP DRAW	
PSI	Spike Amps Draw
50	82
250	96
500	112
750	128
1000	144
1250	160
1500	175
1750	190
2000	204
2250	219
2500	233
2750	246
3000	260



SPIKE BED

PARTS

Table of Contents

PARTS SECTION

Side Rails.....	14
Spikes & Pivot Gates.....	15
Spike Fork Assembly.....	16
Lift Cylinders.....	17
Hoses: Standard, Trough and Coupled.....	18-19
Bed Service Parts.....	20
Decals.....	21
Completing Kit (E/H, Controls & Hardware)..	22
Controls: Corded & Wireless.....	23
E/H Power Unit.....	24
E/H Schematic.....	25
Lights & Mounts.....	26
Electrical Harnesses.....	27-28
Harnesses: OEM to Butler Adapters.....	29-30
Toolboxes.....	31
Mudflaps.....	32
Bed Mounting Kits.....	33
Rear View Camera Mounts.....	33
Bed Lengths for Cake Feeders.....	34

SIDE RAILS

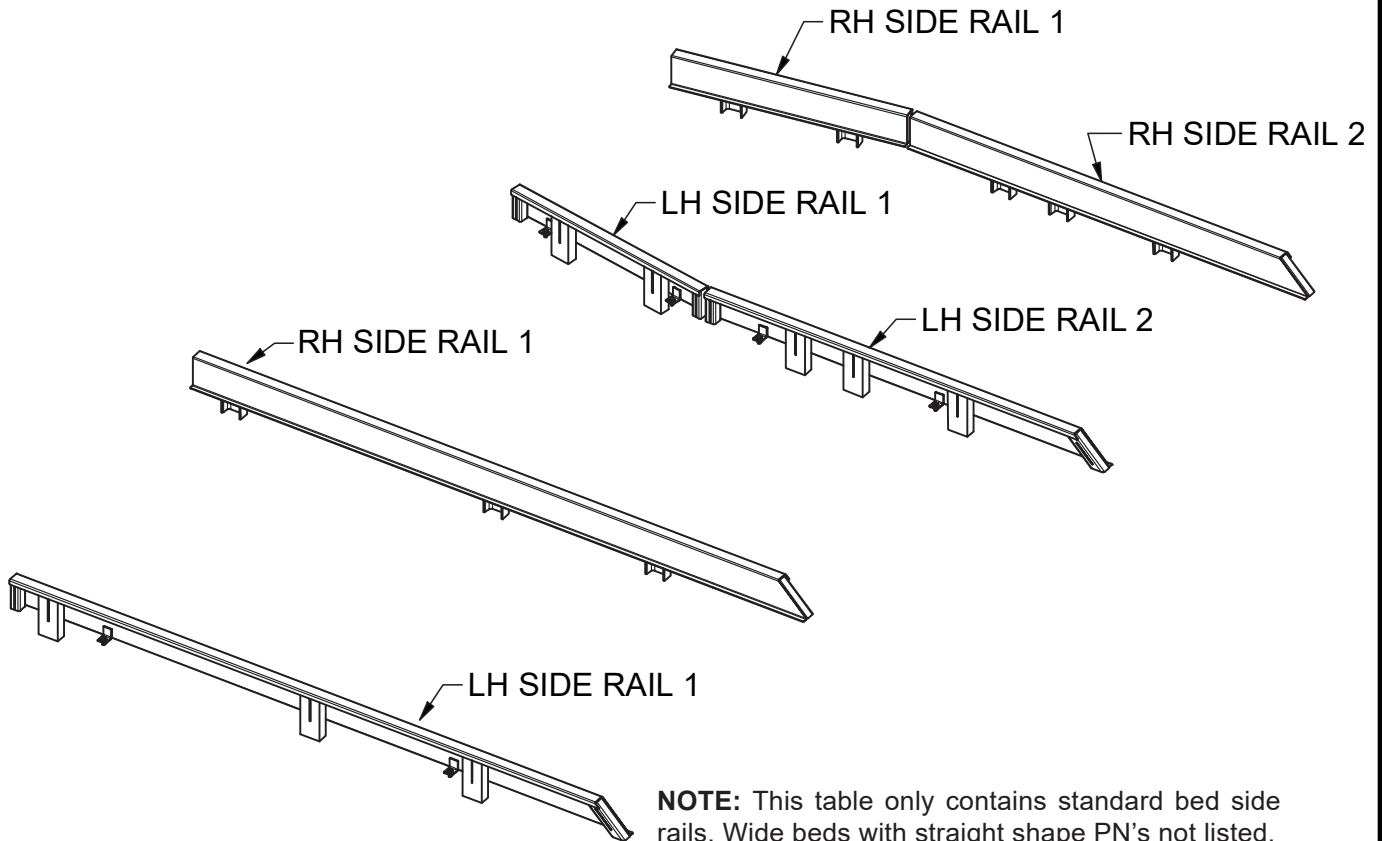

NOTE: This table only contains standard bed side rails. Wide beds with straight shape PN's not listed.

SIDE RAILS					
BED SIZE	BED SHAPE	LH RAIL 1	RH RAIL 1	LH RAIL 2	RH RAIL 2
S80X86	Straight	205209	205208	NA	NA
S80X102	Straight	205199	205200	NA	NA
S80X110	Straight	205213	205214	NA	NA
S80X115	Straight	205255	205256	NA	NA
S84X86	Straight	205209	205208	NA	NA
S84X102	Straight	205199	205200	NA	NA
S84X110	Straight	205213	205214	NA	NA
S84X115	Straight	205255	205256	NA	NA
S90X110	Tapered	205218	205218	205275	205274
S90X115	Tapered	205218	205218	205245	205246
S90X139	Tapered	205218	205218	205277	205278
S94X102	Tapered	205218	205218	205217	205216
S94X110	Tapered	205218	205218	205275	205274
S94X115	Tapered	205218	205218	205245	205246
S94X134	Tapered	205218	205218	205295	205296
S94X139	Tapered	205218	205218	205277	205278
S96X86	Tapered	205299	205299	205300	205301
S96X102	Tapered	205218	205218	205217	205216
S96X110	Tapered	205218	205218	205275	205274
S96X115	Tapered	205218	205218	205245	205246
S96X134	Tapered	205218	205218	205295	205296
S96X139	Tapered	205218	205218	205277	205278

SPIKES & PIVOT GATES

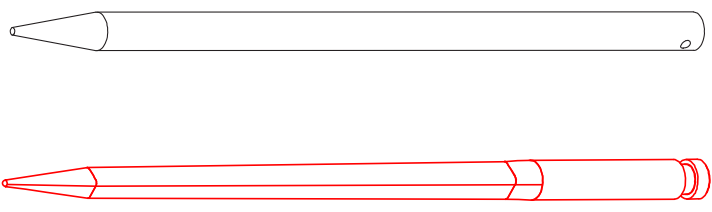

SPIKES		
TYPE	SINGLE	PAIR
Black Round (Bar)	280221	205177
Red (Forged)	212030	205176

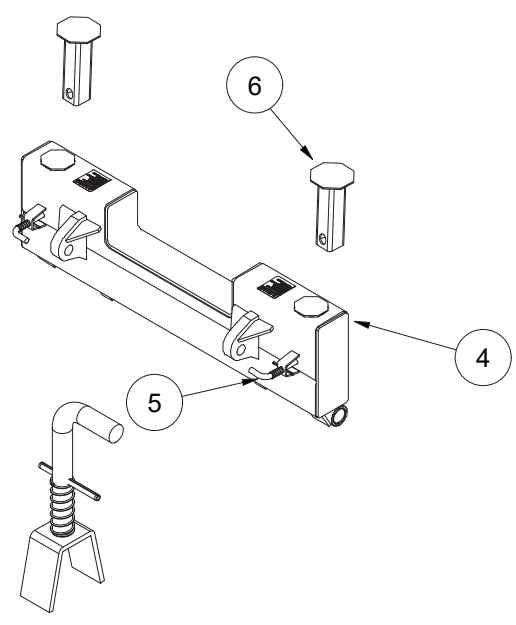
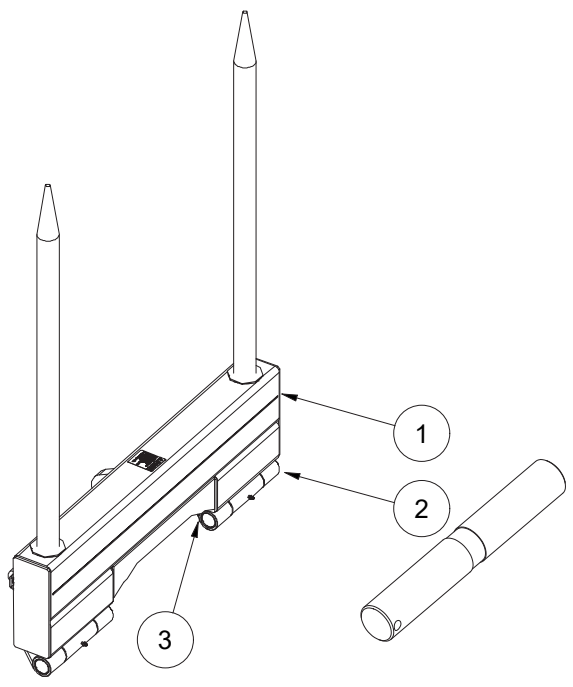

Parts List			
ITEM	QTY	PART #	DESCRIPTION
1	1	205204	Pivot Gate
2	1	280220	Hinge, Pin
3	1	215418	Hinge, Kit (Set of Pins, Plates & Tubes)
4	1	205370	Pivot Trough Gate
5	2	205174	Kit, Spring Pin Kit
6	2	285247	Pivot Spike Plug

SPIKE FORK ASSEMBLY

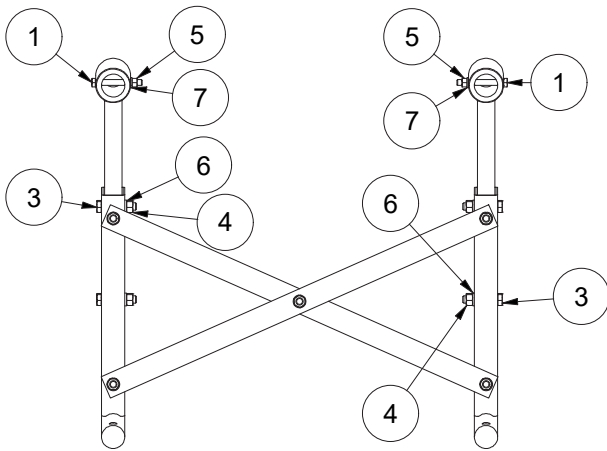
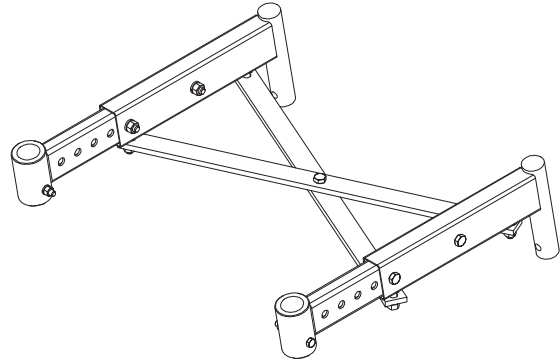
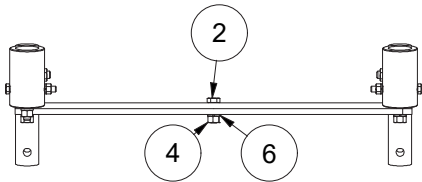

Parts List

ITEM	QTY	PART #	DESCRIPTION
1	2	110003	Bolt, 1/2-13 X 4.0
2	1	110159	Bolt, 5/8-11 X 1.75
3	4	110477	Bolt, 5/8-11 X 3.0
4	9	110597	Nut, 5/8-11 Hex
5	2	110610	Nut, 1/2-13
6	9	110655	Washer, 5/8" Lock
7	2	110666	Washer, 1/2" Lock

LIFT CYLINDER (STANDARD BED)

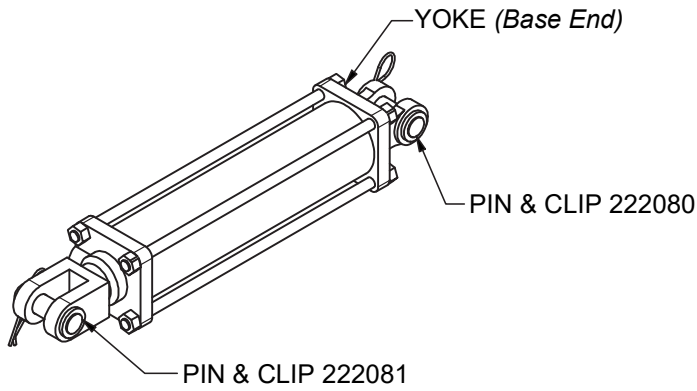

222071 Cylinder, Hydraulic, 3.50 X 1.25 X 12

Lift Cylinder Parts List		
QTY	PART #	DESCRIPTION
1	222071	Lift Cylinder (3.50 x 1.25 x 12)
1	222077	Yoke 3.5 Kit
1	222080	Pin & Clip (1.0 x 2.75)
1	222081	Pin & Clip (1.0 x 3.125)
1	222083	Seal Kit 1.25 x 3.5
1	?	Clevis, Rod End, Lift Cylinder

LIFT CYLINDERS (TROUGH BED)

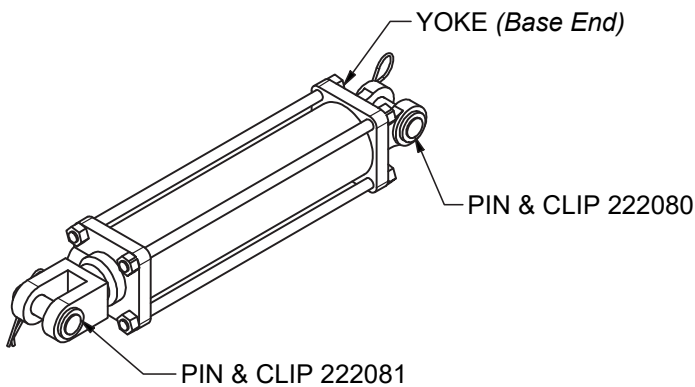

X2: 222108 Cylinder, Hydraulic, 2.50 X 1.06 X 12

Lift Cylinder Parts List		
QTY	PART #	DESCRIPTION
1	222108	Lift Cylinder (3.50 x 1.25 x 12)
1	?	Yoke 2.5 Kit
1	222080	Pin & Clip (1.0 x 2.75)
1	222081	Pin & Clip (1.0 x 3.125)
1	?	Seal Kit 1.06 x 2.5
1	?	Clevis, Rod End, Lift Cylinder

HOSES (STANDARD BED)

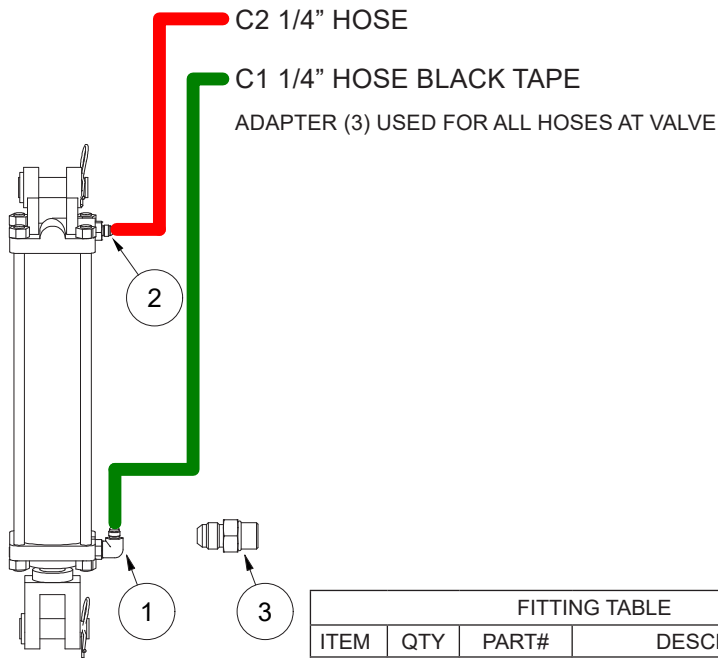

ITEM	QTY	PART#	DESCRIPTION
1	1	120134	Adapter 6mj-8mb90
2	1	120239	Adapter 6mj-8mb
3	2	120319	Adapter 6mj-6mb

BED	HOSE 1 (RED)	HOSE 2 (GREEN)
S80X86	220757	220758
S80X102	220757	220758
S80X110	220757	220758
S80X115	220757	220758
S84X86	220757	220758
S84X102	220757	220758
S84X110	220757	220758
S84X115	220757	220758
S90X110	220757	220758
S90X115	220757	220758
S90X139	220764	220792
S94X102	220757	220758
S94X110	220757	220758
S94X115	220757	220758
S94X134	220764	220792
S94X139	220764	220792
S96X86	220757	220758
S96X102	220757	220758
S96X110	220757	220758
S96X115	220757	220758
S96X134	220764	220792
S96X139	220764	220792

HOSES (TROUGH BED)

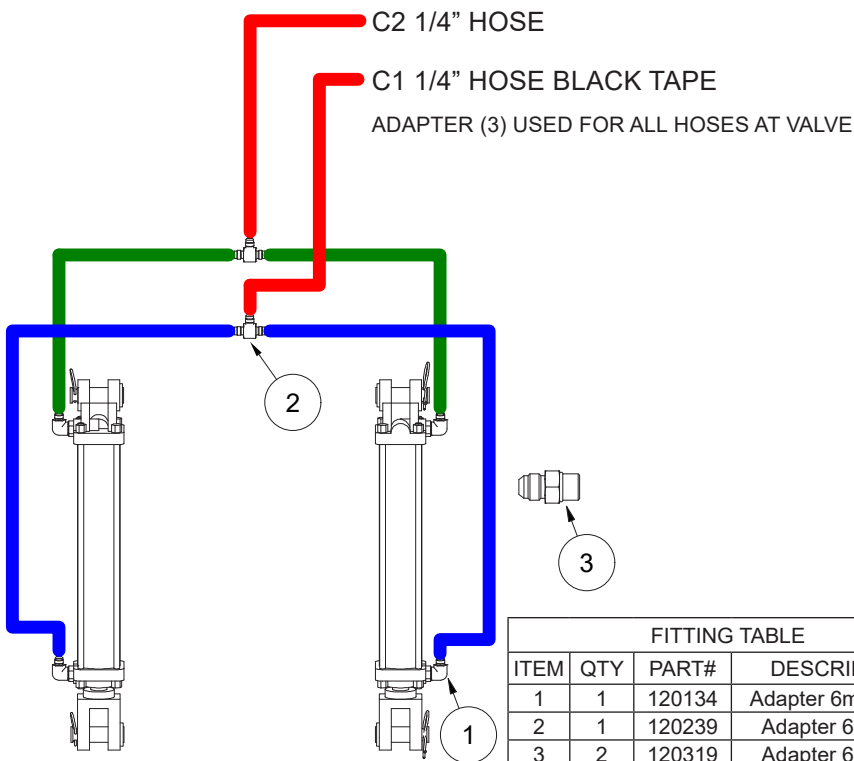

ITEM	QTY	PART#	DESCRIPTION
1	1	120134	Adapter 6mj-8mb90
2	1	120239	Adapter 6mj-8mb
3	2	120319	Adapter 6mj-6mb

BED	HOSE 1 (RED)	HOSE 2 (GREEN)	HOSE 3 (BLUE)
S80X86	220757	220808	220809
S80X102	220757	220808	220809
S80X110	220757	220808	220809
S80X115	220757	220808	220809
S84X86	220757	220808	220809
S84X102	220757	220808	220809
S84X110	220757	220808	220809
S84X115	220757	220808	220809
S90X110	220757	220808	220809
S90X115	220757	220808	220809
S90X139	220764	220808	220809
S94X102	220757	220808	220809
S94X110	220757	220808	220809
S94X115	220757	220808	220809
S94X134	220764	220808	220809
S94X139	220764	220808	220809
S96X86	220757	220808	220809
S96X102	220757	220808	220809
S96X110	220757	220808	220809
S96X115	220757	220808	220809
S96X134	220764	220808	220809
S96X139	220764	220808	220809

HOSES (REAR COUPLERS)

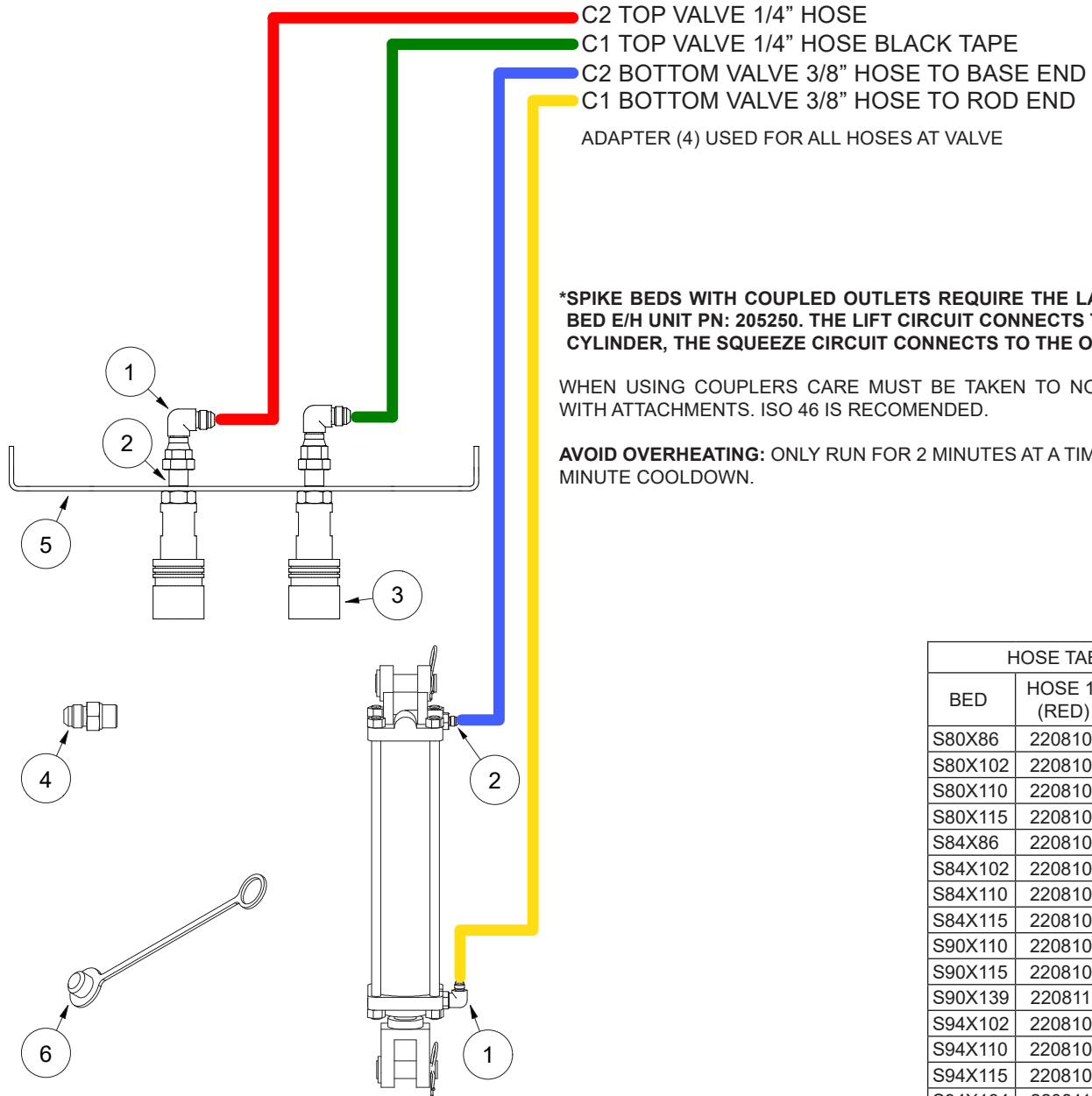

HOSE TABLE		
BED	HOSE 1 (RED)	HOSE 2 (GREEN)
S80X86	220810	220810
S80X102	220810	220810
S80X110	220810	220810
S80X115	220810	220810
S84X86	220810	220810
S84X102	220810	220810
S84X110	220810	220810
S84X115	220810	220810
S90X110	220810	220810
S90X115	220810	220810
S90X139	220811	220811
S94X102	220810	220810
S94X110	220810	220810
S94X115	220810	220810
S94X134	220811	220811
S94X139	220811	220811
S96X86	220810	220810
S96X102	220810	220810
S96X110	220810	220810
S96X115	220810	220810
S96X134	220811	220811
S96X139	220811	220811

PARTS LIST			
ITEM	QTY	PART#	DESCRIPTION
1	2	120218	Adapter 6mj-6fjxb90
2	2	120743	Adapter 8mb-6mj Bulkhead
3	2	120581	Coupler, Female Orb
4	4	120319	Adapter 6mj-6mb
5	1	281011	Mounting Bracket
6	2	420051	Dust Cap

BED SERVICE PARTS

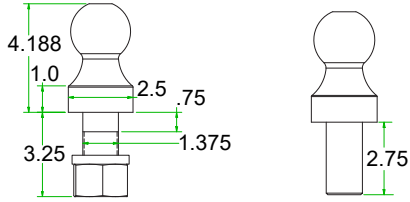

Part #	Description
	Ball Hitch
212032	2.3125" Ball, 1.375 x 3.25" Bolt, 1.00" Rise
281080	2.3125" Ball 1.375 x 2.75" Bolt, 1.00" Rise

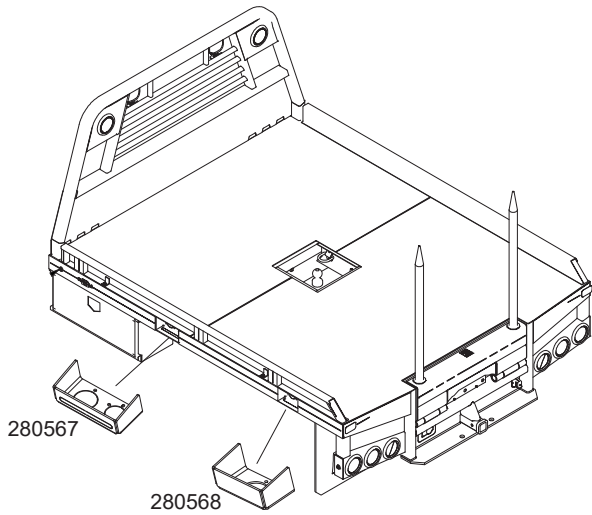

Part #	Description
	Fuel Fill Brackets
280567	Bracket, Fuel and DEF Fill (Not Painted)
280568	Bracket, Fuel Fill, C&C Rear (Not Painted)

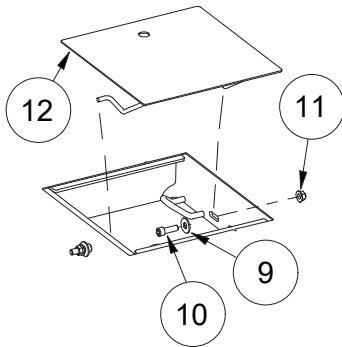

New Gooseneck Well Door Kit 205483 (Late 2022 forward)			
ITEM	QTY	PART #	DESCRIPTION
9	2	110244	Bolt, 1/2-13 X 1.5 Shcs
10	2	110588	Nut, 1/2-13 Wiz Flange
11	2	110658	Washer, 1/2" Flat Standard
12	1	285850	Door, Assy, 5th Wheel

One piece rod with hardware to secure.

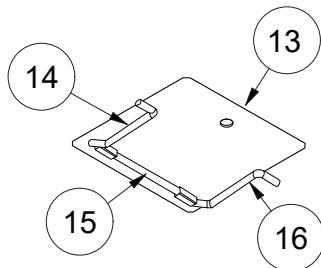

Old Gooseneck Well Door Kit 285252 (2022 & earlier)			
ITEM	QTY	PART #	DESCRIPTION
13	1	285233	Door, Wa Gooseneck Well
14	1	280151	Hinge, Straight Rod
15	1	280150	Hinge, Front Rod
16	1	280154	Hinge, Rear Rod

Three piece rod, hinge not welded.

DECALS

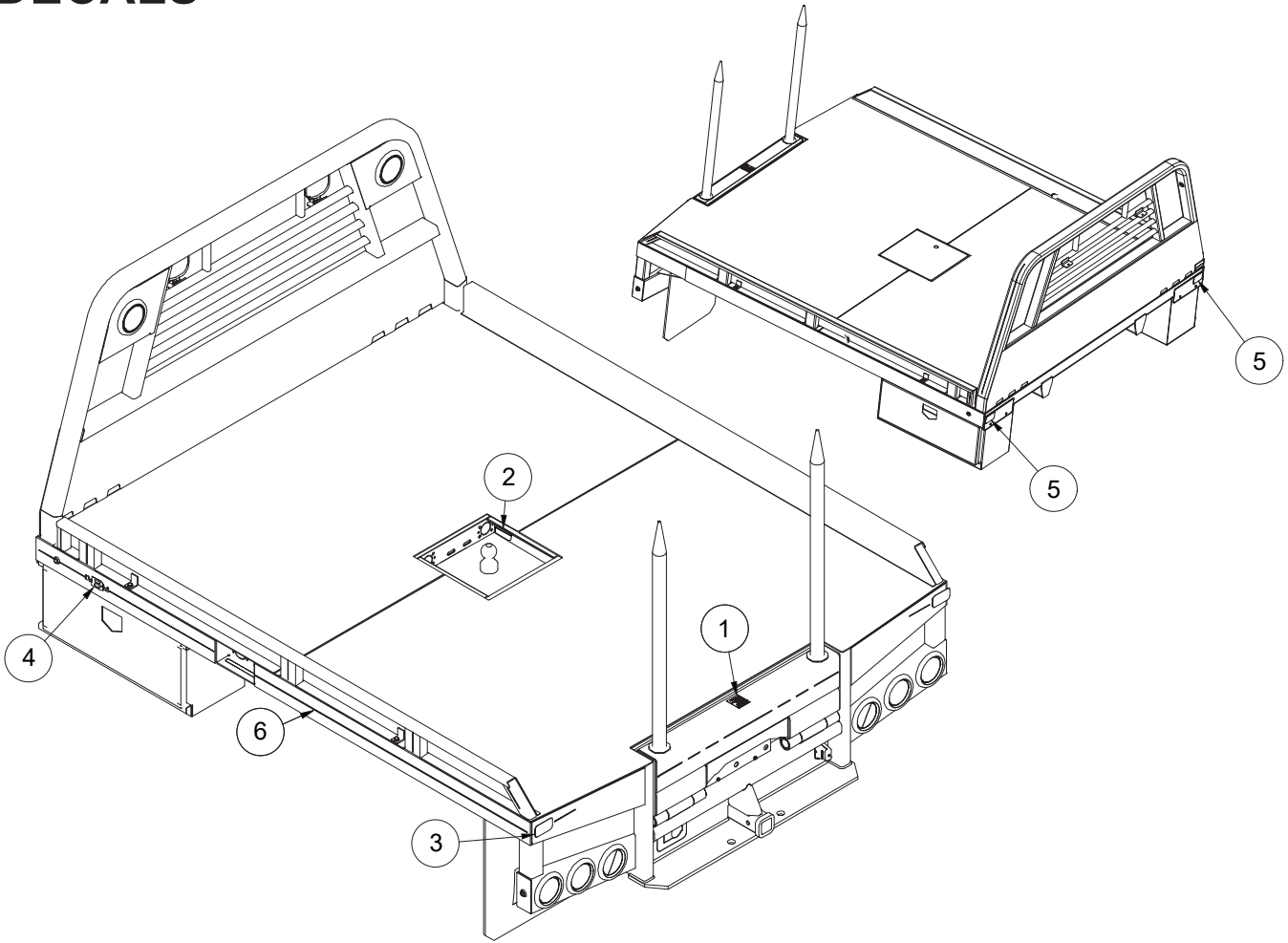

⚠ DANGER
 KEEP AWAY WHILE
 MACHINE IS IN
 OPERATION TO
 REDUCE
 POSSIBILITY OF
 SERIOUS
 PERSONAL INJURY.
200144

1

⚠ NOTICE
 MAX TONGUE WEIGHT = 7,500 LBS
 DO NOT EXCEED VEHICLE GVW AND/OR
 MAX AXLE WEIGHT PER VEHICLE OWNER'S
 MANUAL
200472

2



3



4

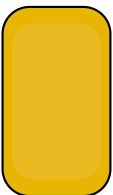

5

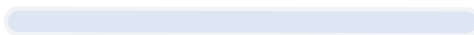

6

Parts List			
ITEM	QTY	PART #	DESCRIPTION
1	1	200144	Decal, Danger
2	1	200472	Decal, Gooseneck Tongue Weight
3	2	202138	Decal, Red Reflector 2 X 3.5
4	2	202140	Decal, Butler
5	2	202139	Decal, Amber Reflector 2 X 3.5
6	1	202148	Decal, Pinstripe, White 150' Roll

SPIKE BED COMPLETING KIT

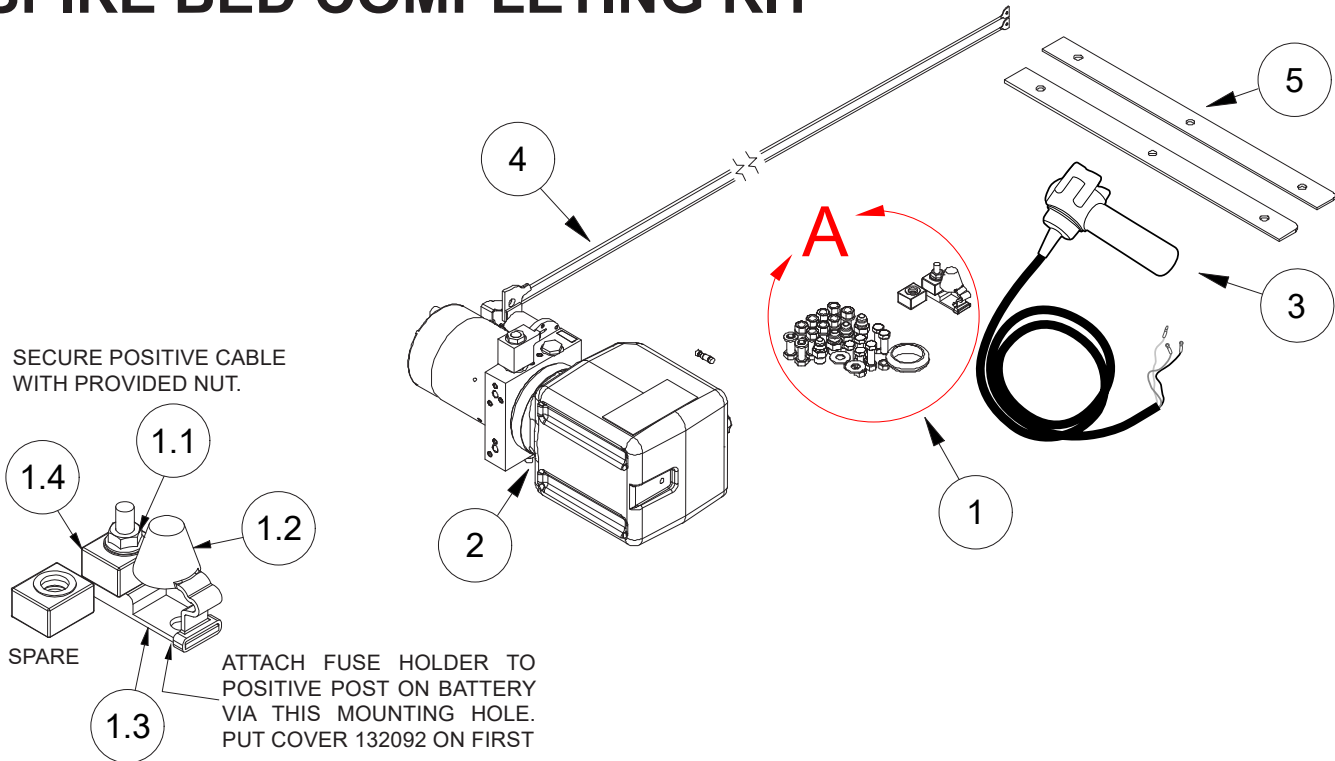

DETAIL A

HARDWARE KIT: 205411



BOLT KIT: 205178

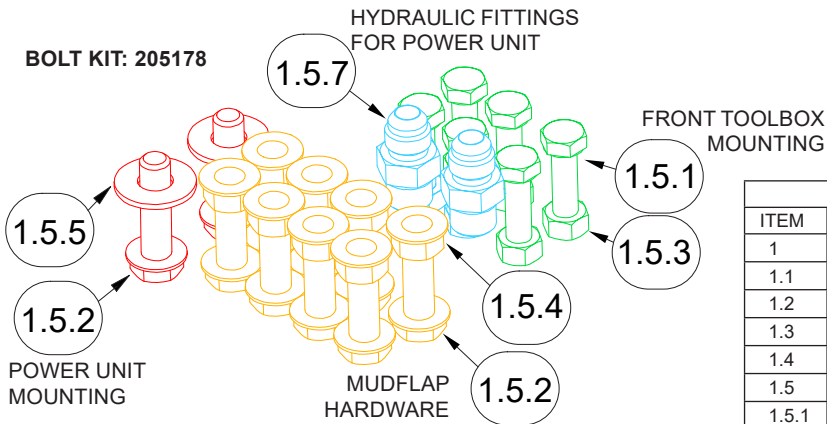

Parts List				KIT: 205251
ITEM	QTY	PART #	DESCRIPTION	
1	1	205411	Kit, Hardware (Spike Bed)	
1.1	1	110141	Nut, M8 X 1.25 Wizflange	
1.2	1	132092	Fuse Cover, Buss CFcover-1R	
1.3	1	132093	Fuse Holder, Buss CFBAR1-M8XSP	
1.4	2	132094	Fuse 200 Amp, Buss MRBF-200	
1.5	1	205178	Kit, Bolt (Spike Bed)	
1.5.1	6	110423	Bolt, 5/16-18 X 1.0	
1.5.2	10	110440	Bolt, 3/8-16 X 1, Wiz Flange	
1.5.3	6	110608	Nut, 5/16-18	
1.5.4	8	110645	Nut, 3/8-16 Wiz Flange	
1.5.5	2	110676	Washer, 3/8" Flat Standard	
1.5.6	1	112123	Grommet, Rubber 1 1/2 X 1/2 Round	
1.5.7	2	120319	Adapter, 6mj-6mb	
2	1	222075	Assembly, Power Unit (Low/Spike Bed)	
3	1	232151	Hand Control, Butler Spike Bed	
4	1	233007	Kit, Cables Power & Ground, Long	
5	2	281265	Bracket, Mudflap, Painted	

BUTLER SPIKE CORDED & WIRELESS: BUCHER VALVE

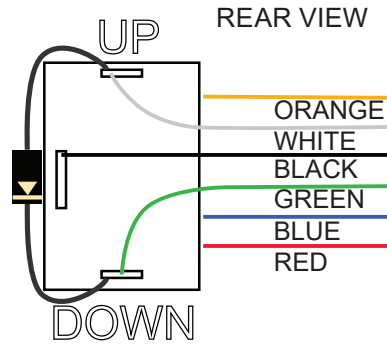
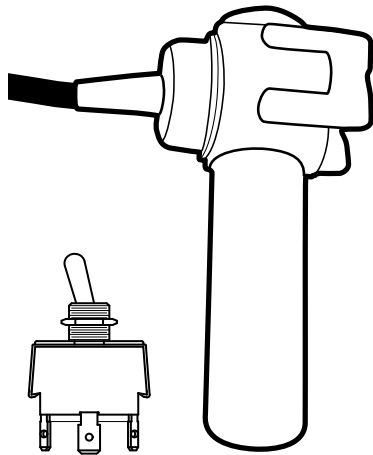

CORDED Parts List		
QTY	PART #	DESCRIPTION
1	232151	Wired, Hand Control One Switch
2	232172	Switch, SB Hand Control

WIRELESS (Lodar) Parts List		
QTY	PART #	DESCRIPTION
1	233009	*RECEIVER/TRANSMITTER
1	232165	Transmitter
1	233014	Receiver/Transmitter Assy (new installs)

WIRELESS KIT (FIRST TIME INSTALL) KIT: 233014		
QTY	PART #	DESCRIPTION
1	233009	Transmitter & Receiver, 2 Function Lodar
1	233013	Kit, Wireless Hardware (Arm Bed)
1	110308	Bolt, 5/16-18 X 0.5, Gr8
2	110344	Screw, 8-32x1.5 Pan Head Pkgs
2	110345	Nut, 8-32 Lock Nylon
1	132001	Fuse Holder, Atc, 14 Ga., Mini
2	132147	Terminal, Butt Connect 16-14, Heat Shink
1	132165	Terminal, Female Bullet, 16-14, Nylon
1	132170	Terminal, Male Bullet, 16-14, Nylon
1	132178	Fuse, Mini 7.5 Amp

*Receiver NOT SOLD separately. Must buy kit.

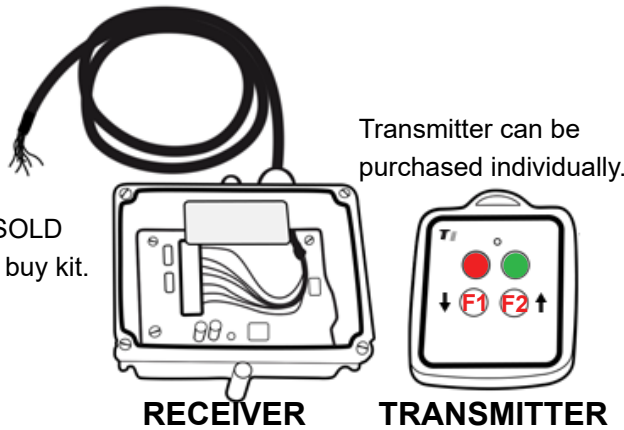

For synchronizing (teaching, homing, pairing) refer to **page 8**

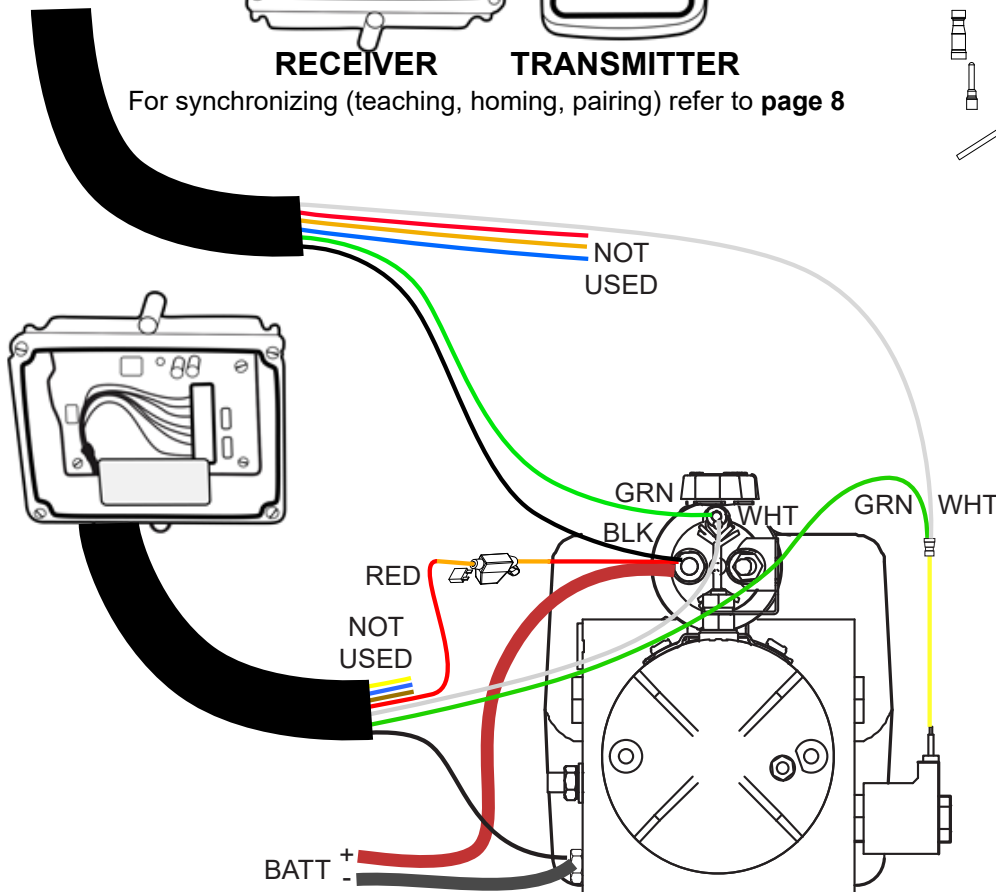
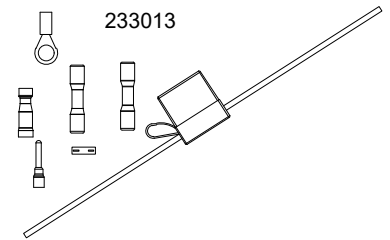

E/H UNIT

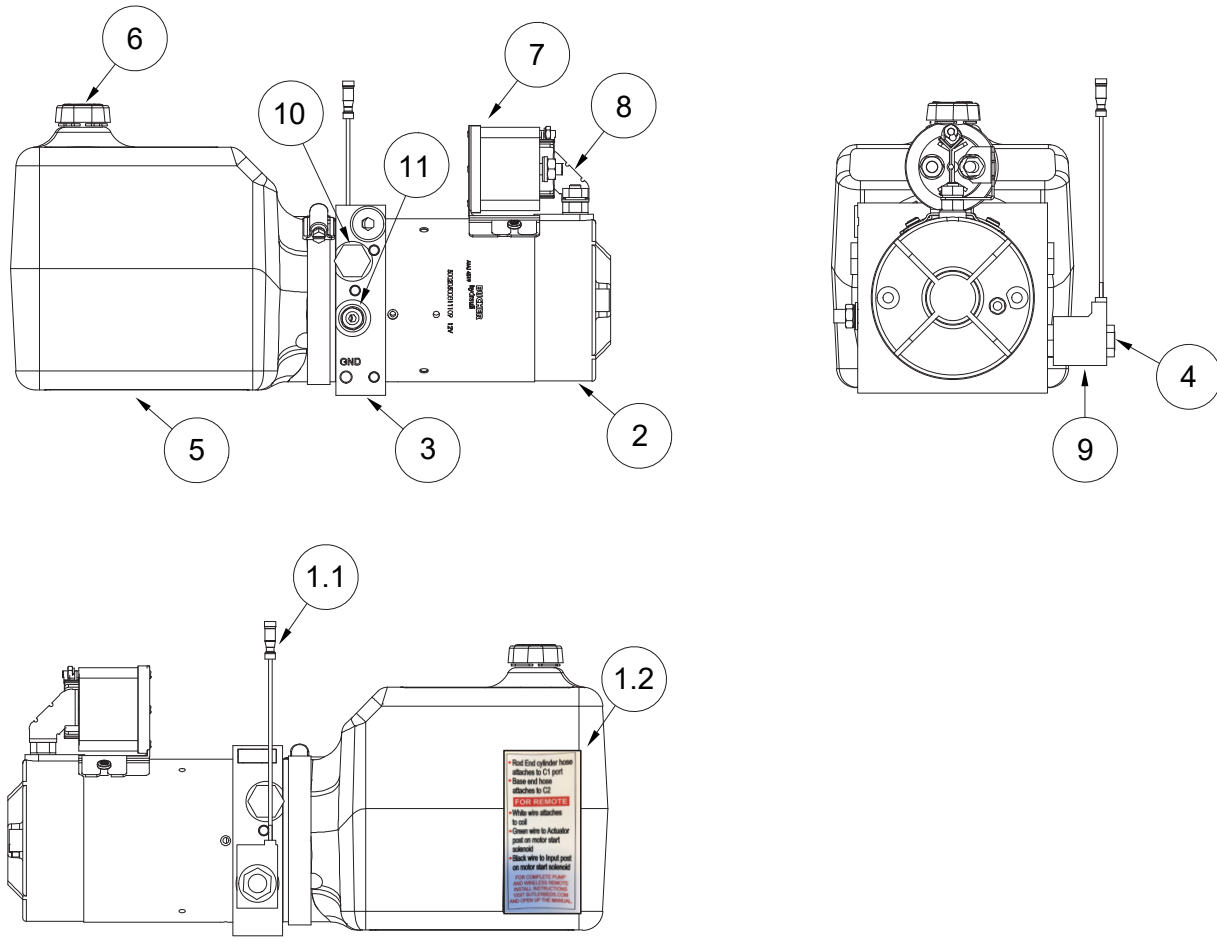

⚠ WARNING ⚠
 This battery area/compartiment is designed for the use of non-vented batteries only. Do not place a battery that requires venting into this area/compartiment. Vented batteries can release poisonous and flammable gases. Can lead to a fire or explosion and result in death or serious injury.

Parts List			KIT: 222075
ITEM	QTY	PART #	DESCRIPTION
1	1	222075	E/H Unit, Spike Bed Bucher 3554-0109
1.1	1	132165	Terminal, Female Bullet, 16-14, Nylon
1.2	1	202142	Decal, 2x4.5 Spike Bed Remote Instructions
1.3	1	202180	Decal, Non-Vented Battery Warning.
2	1	222073	Motor, Electric Spike Bed 12v
3	1	222092	Pump, Hydraulic Spike Bed
4	1	222093	Valve, Cartridge Spike Bed
5	1	212034	Tank, Hydraulic Bucher
6	1	212044	Cap, Hydraulic Tank Bucher
7	1	232089	Solenoid, 3 Pole, Heavy Duty
8	1	232180	Strap, Solenoid Connecting
9	1	212033	Valve, Coil Spike Bed
10	1	222106	Check Valve
11	1	222107	Valve, Relief Spike Bed

E/H SCHEMATIC

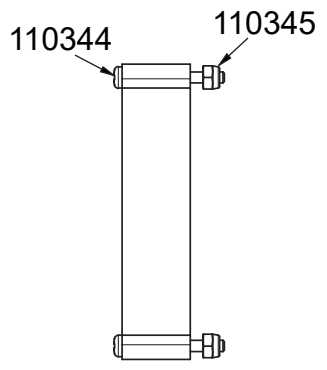
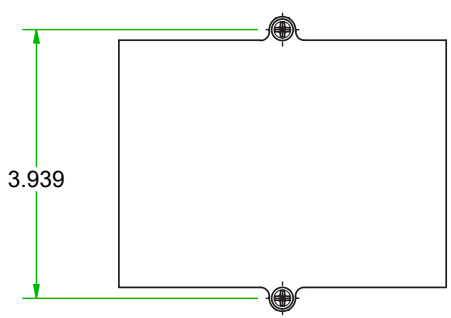
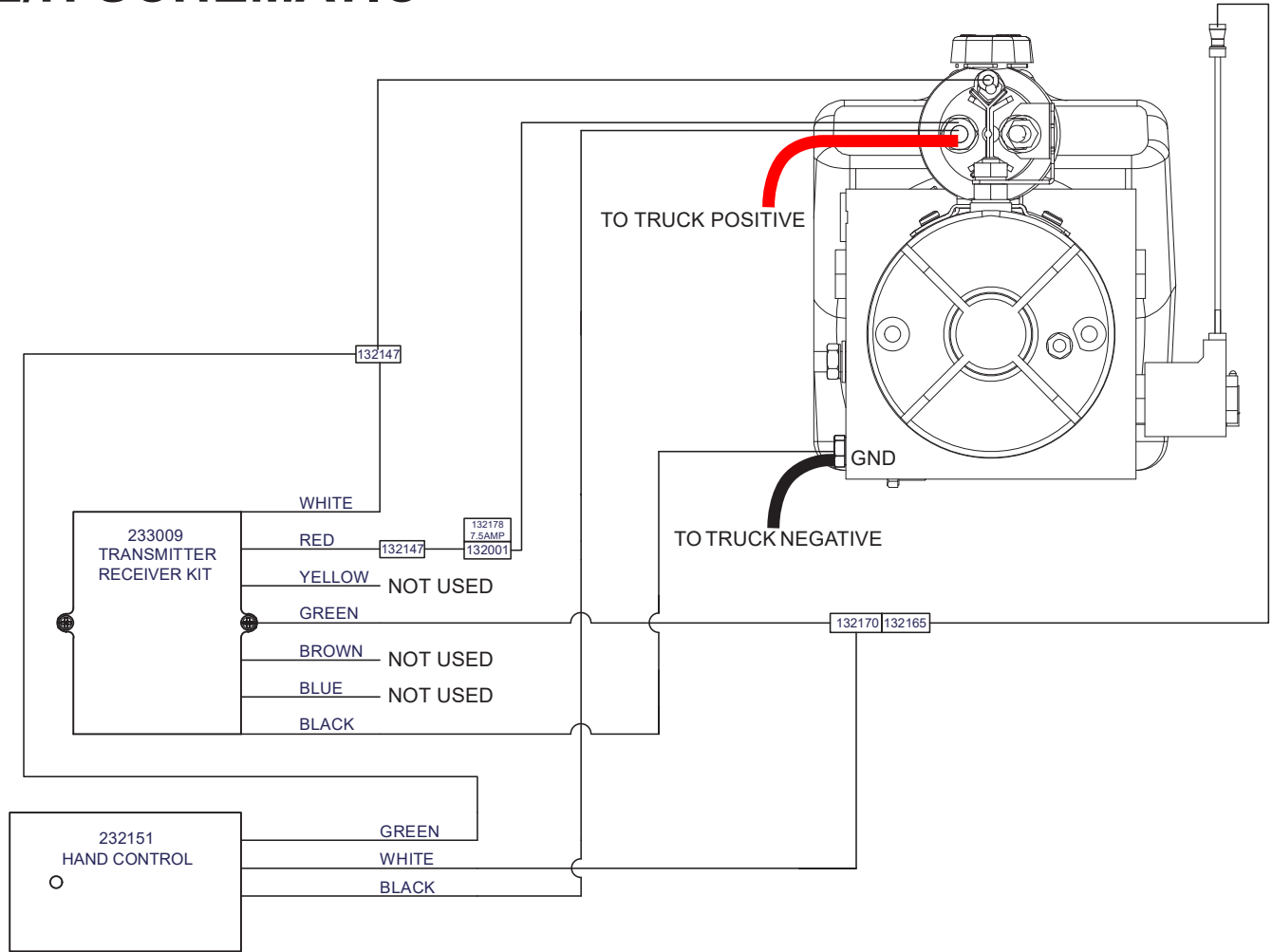

- MOUNT TRANSMITTER AS FAR AS FEASIBLE IN UPPER RH CORNER OF PASSENGER SIDE TOOLBOX.
- DRILL Ø 0.20 HOLES PER NOTED DIMENSIONS
- USE HARDWARE KIT 233015 TO MOUNT

LIGHTS & MOUNTS

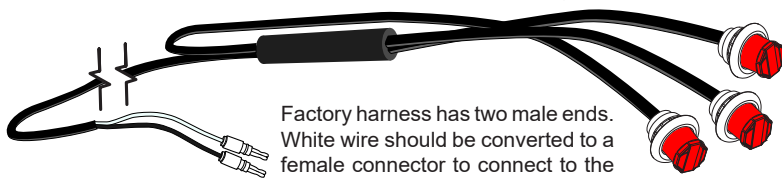
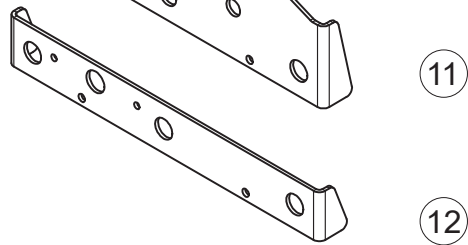
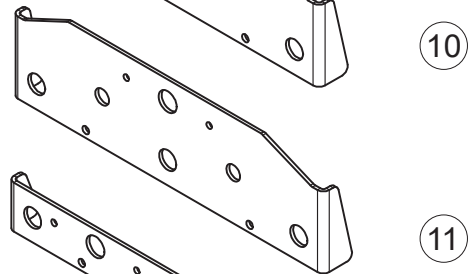
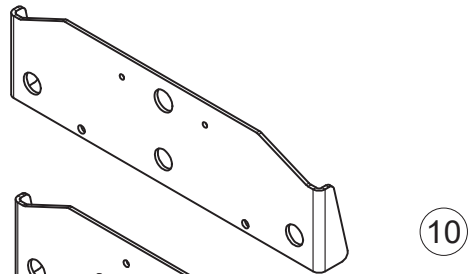
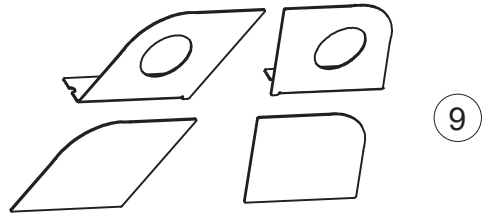
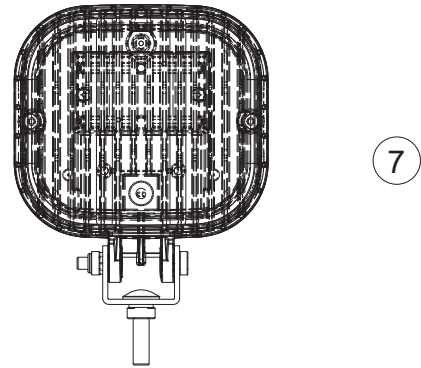
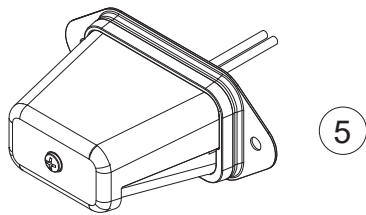
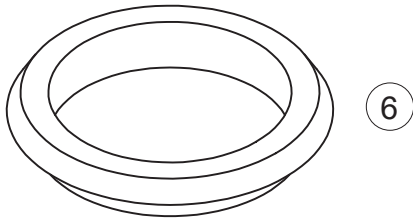
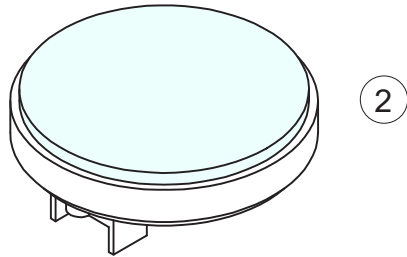
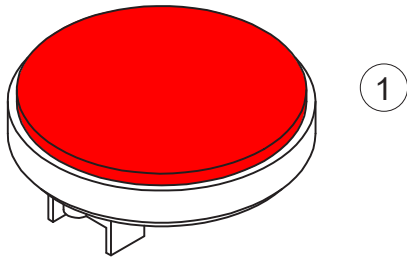

Factory harness has two male ends. White wire should be converted to a female connector to connect to the 232157 harness.

LIGHTS			
ITEM	QTY	PART#	DESCRIPTION
1	6	232144	Light, LED 4" Red
2	2	232145	Light, LED 4" Clear
3	2	232147	Light, LED 3/4" Red
4	2	232148	Light, LED 3/4" Amber
5	1	232154	Light, Tag Clear
6	8	232146	Grommet, Light
7	2	232167	Light, Work
8	1	232170	Light Harness, LED 3/4" Red 3pc
9	1	225034	Kit, STT Light Brackets
10	1	280637	Plate, Light (Standard Spike)
11	1	281011	Plate, Light (Rear Couplers)
12	1	281059	Plate, Light (Trough Spike)

ELECTRICAL HARNESSES

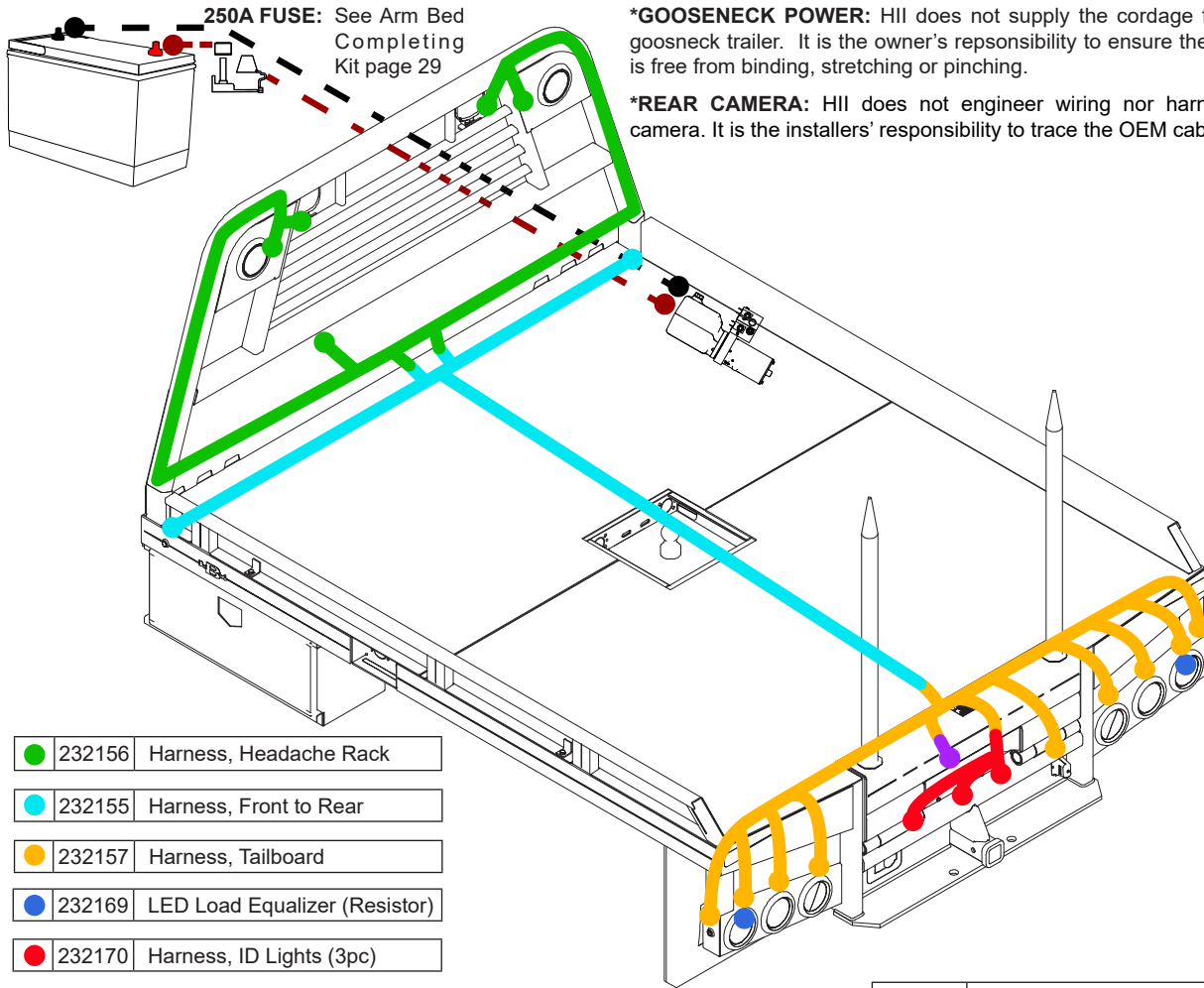

***GOOSENECK POWER:** HII does not supply the cordage for powering a goosneck trailer. It is the owner's responsibility to ensure their power cable is free from binding, stretching or pinching.

***REAR CAMERA:** HII does not engineer wiring nor harnesses for the camera. It is the installers' responsibility to trace the OEM cable to re-attach.

- 232156 Harness, Headache Rack
- 232155 Harness, Front to Rear
- 232157 Harness, Tailboard
- 232169 LED Load Equalizer (Resistor)
- 232170 Harness, ID Lights (3pc)
- OEM to Deweze Adapters
- E/H Cables (see E/H section)

PART#	DESCRIPTION
112084	Edge Molding
112125	Grommet, Nylon 1/4

● ● EH Battery & Ground 2ga cable

Factory harness has two male ends. White wire should be converted to a female connector to connect to the 232157 harness.

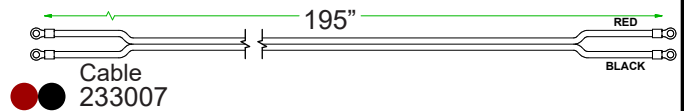

● ● Cable 233007



● Harness 232170

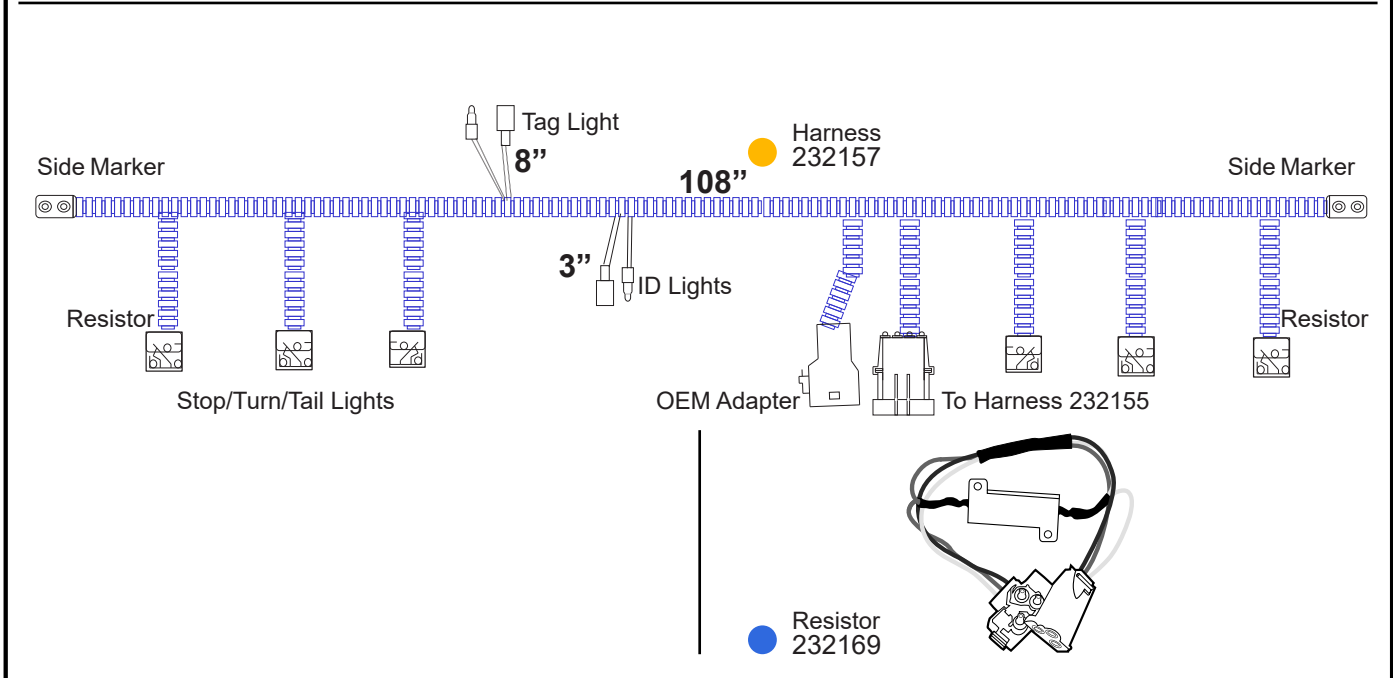
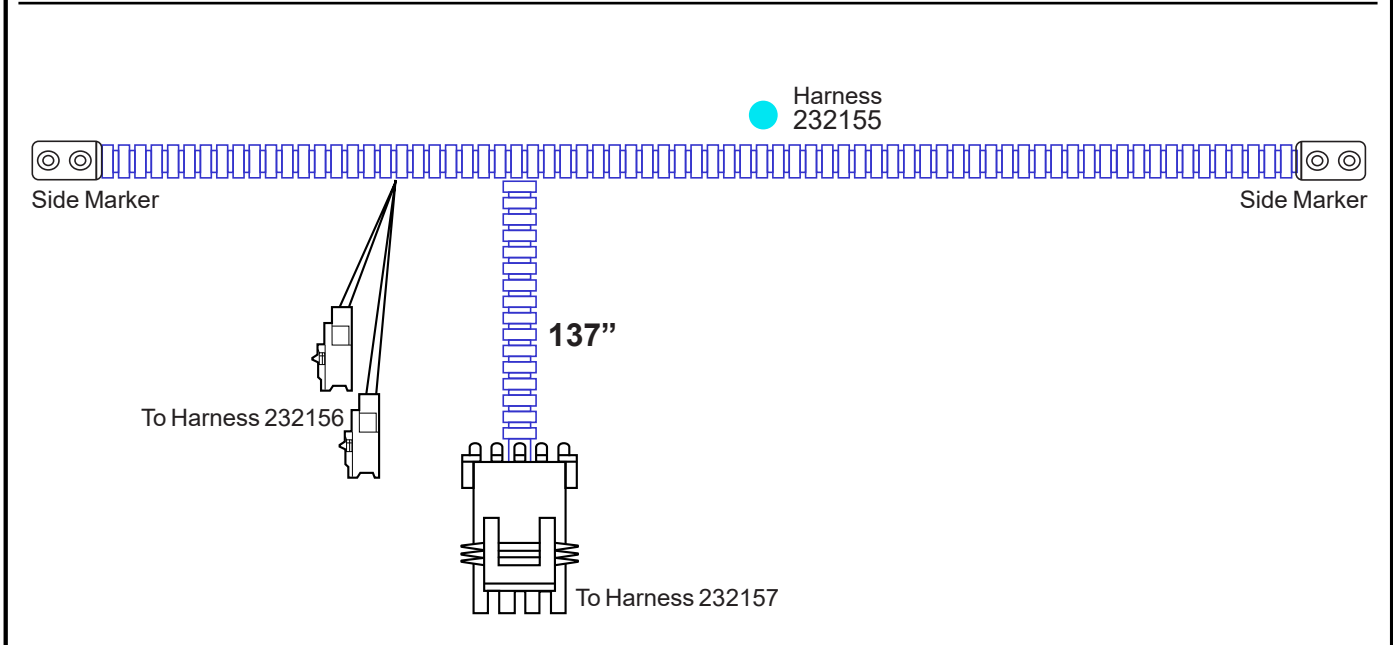
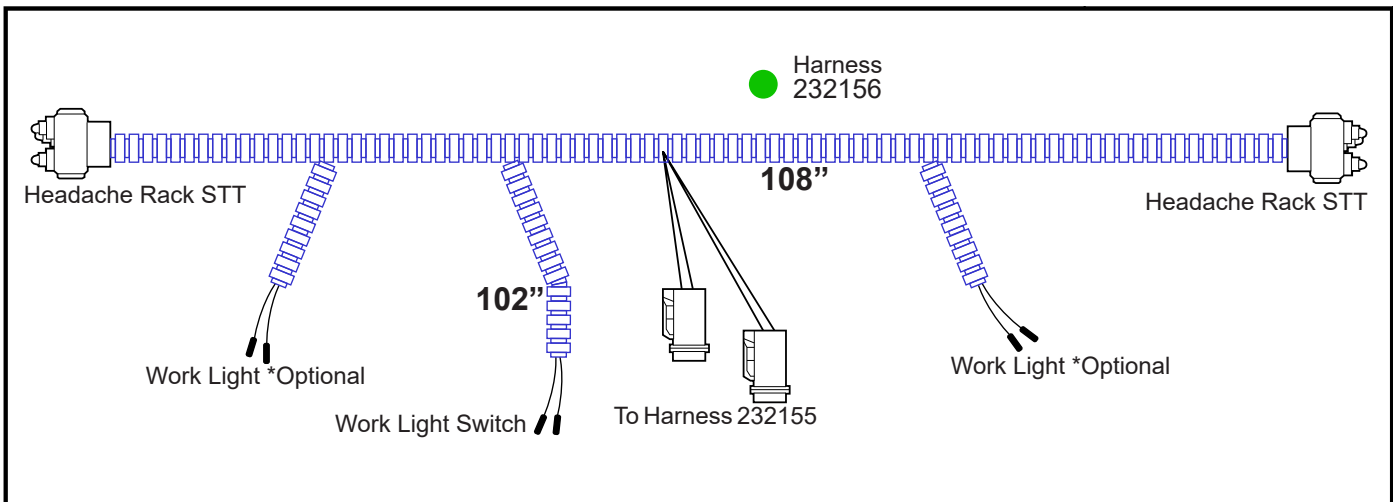

Butler to OEM Harness Adapters					
PART#	DESCRIPTION	MAKE	TYPE	START YR	END YR
232161	Harness Adapter, FD CC	Ford	CC	1999	
232176	Harness Adapter, FD Box Delete, 2008-10	Ford	BTO	2008	2010
232160	Harness Adapter, FD Box Delete, 2011-16	Ford	BTO	2011	2016
232177	Harness Adapter, FD Box Delete, 2017-19	Ford	BTO	2017	2019
232185	Harness Adapter, FD Box Delete, 2020-22	Ford	BTO	2020	2022
232192	BLIS add-on for 232185 (Cut & splice purple & red wires from 20 pin into 232192.)	Ford	BLIS	2020	2022
232234	Harness Adapter, FD Box Delete W/BLIS 23+	Ford	BTO	2023	
232174	Harness Adapter, GM 02-14 w/3rd Brake	GM	ALL	2002	2014
232163	Harness Adapter, GM 02-14 No 3rd Brake	GM	ALL	2002	2014
232158	Harness Adapter, GM 2015 ONLY	GM	ALL	2015	2015
232159	Harness Adapter, GM 2016-2019	GM	ALL	2016	2019
232179	Harness Adapter, 2019 MD Dty 4500-6500	GM	ALL	2019	
232187	Harness Adapter, GM CC 2020+	GM	CC	2020	
232178	Harness Adapter, 2020 GM 2500-3500	GM	ALL	2020	
232238	Harness Adapter, GM BTO	GM	BTO	2024	
232164	Harness Adapter, Ram CC	Dodge	CC	1999	
232233	Harness Adapter, Ram (LED)	Dodge	BTO	2016	
232193	Harness Adapter, Ram Box Delete, 2019+	Dodge	BTO	2019	
232162	Harness Adapter, Generic	ALL	ALL	1999	
232155	Harness, Front	ALL	ALL	ALL	ALL
232157	Harness, Rear	ALL	ALL	ALL	ALL
232156	Harness, Headache Rack	ALL	ALL	ALL	ALL

DODGE

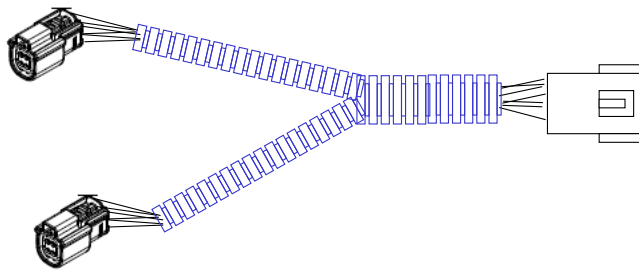

Harness
232193

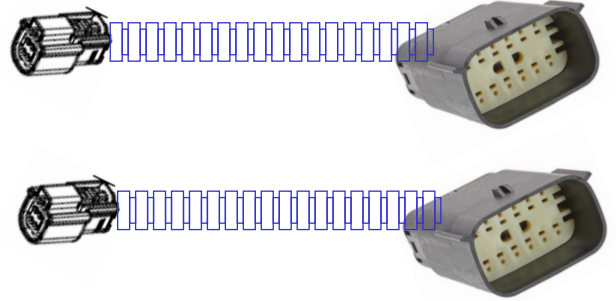

Harness
232233

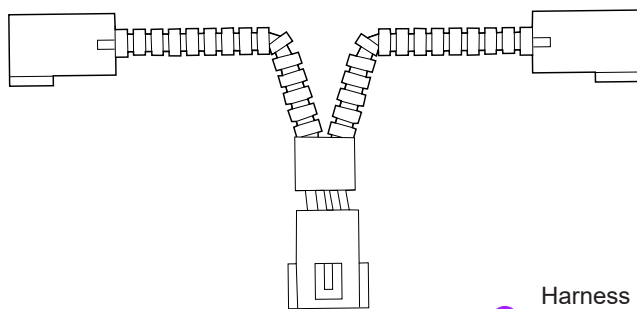

Harness
232164



GENERIC (BLUNT CUT)

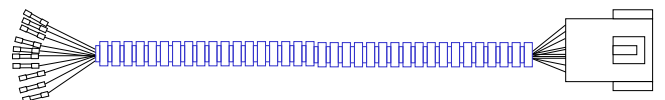

Harness
232162



FORD

● OEM to Deweze Adapters

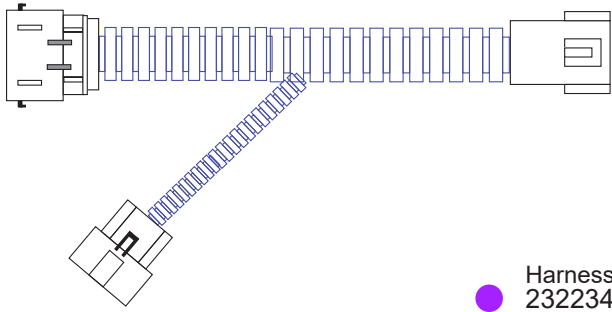

● Harness
232234

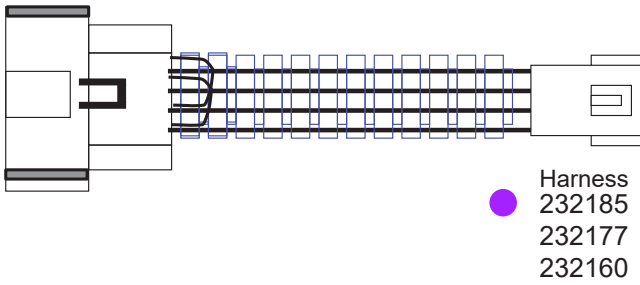

● Harness
232185
232177
232160

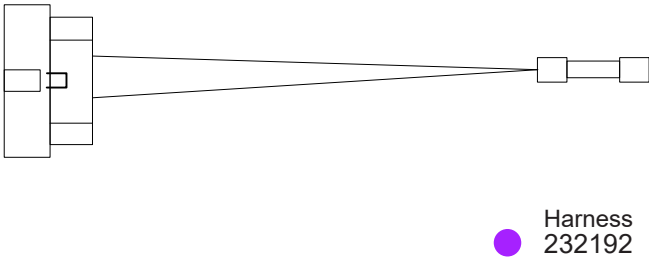

● Harness
232192

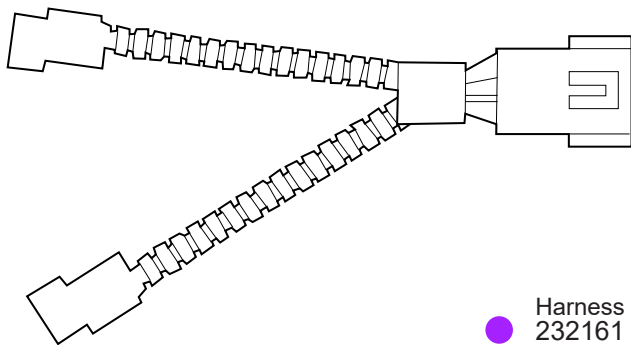

● Harness
232161

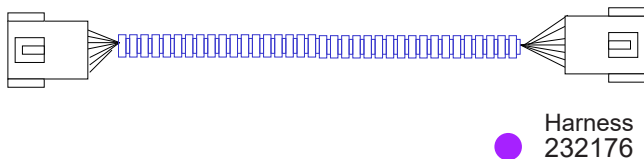

● Harness
232176

CHEVY

● OEM to Deweze Adapters

Purple wires only for fast flashing issue. See pg. <?>

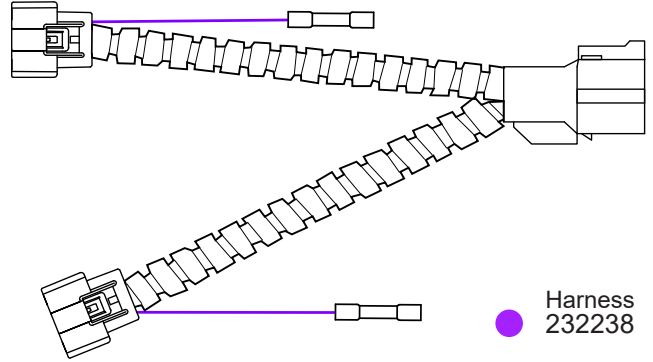

● Harness
232238

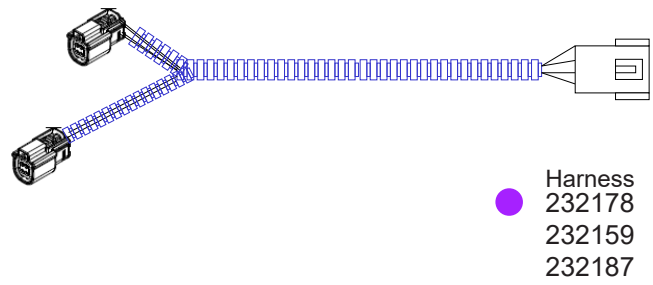

● Harness
232178
232159
232187

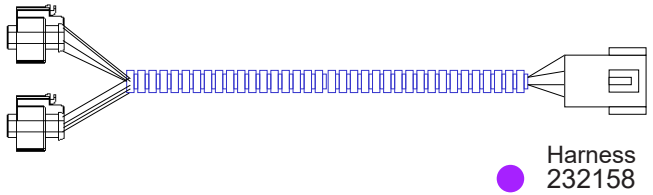

● Harness
232158

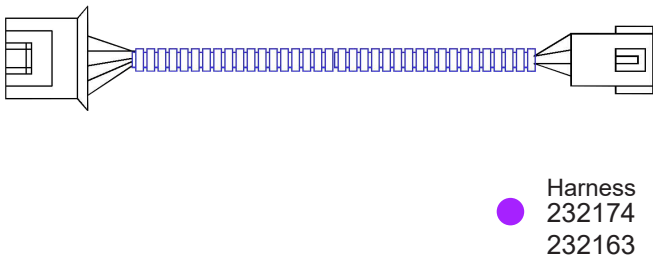

● Harness
232174
232163

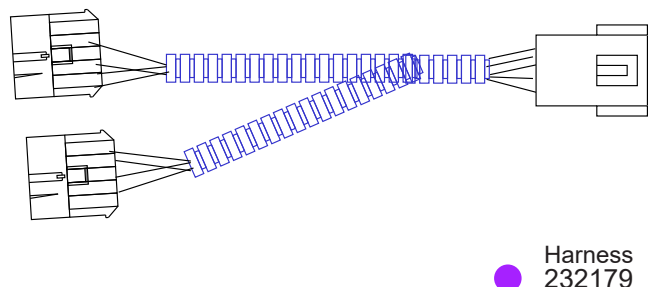

● Harness
232179

TOOLBOXES

FRONT TOOLBOX			REAR TOOLBOX		
SIZE	LH PART #	RH PART #	SIZE	LH PART #	RH PART #
18"	282004	282023	20"	282017	282018
20"	282005	282006	24"	282019	282020
30"	282001	282002			
36"	282008	282022			

QTY	PART #	DESCRIPTION
Chart	102030	Toolbox Seal (sold by foot)
1	102053	Plug, Button 1.00
1	282011	Toolbox Latch
8	110440	Bolt, 3/8-16 x 1 GR5 Zn
8	110676	Washer 3/8 Lock Zn
8	110645	Nut, 3/8-16 GR5 Zn
2	112123	Grommet, Ruber 1 1/2 ID

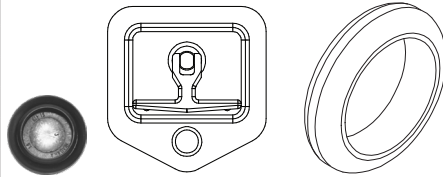

TBX Size	Seal (feet)
18	5
20	5.5
24	6
30	7
36	8

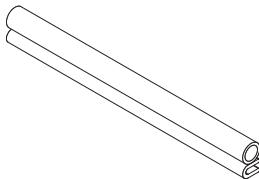

REAR TOOLBOXES

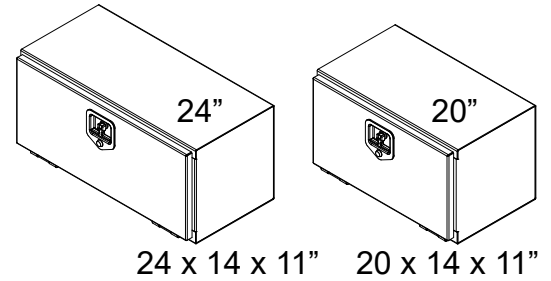

FRONT TOOLBOXES

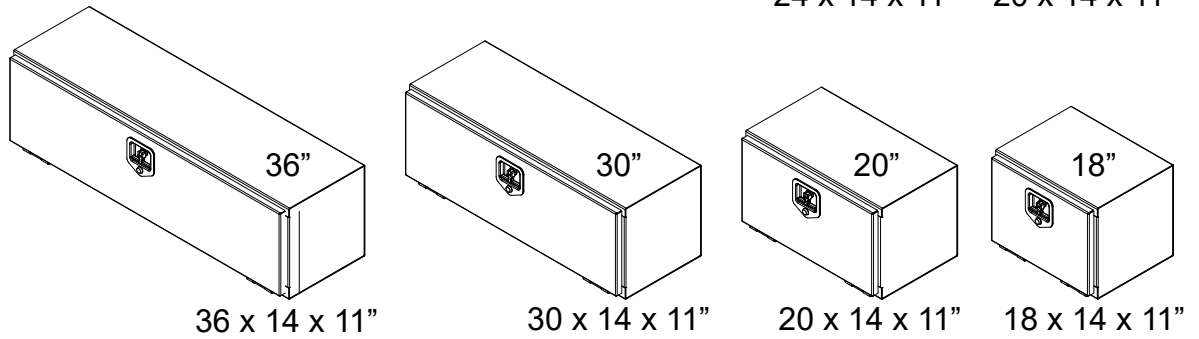

282003
DUAL LID
72 x 12.8 x 16"

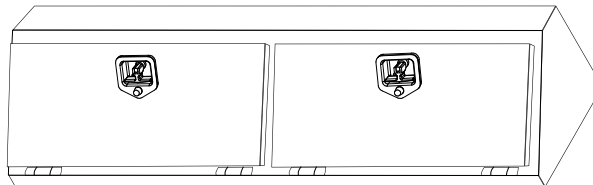

282021
SINGLE LID
79 x 21.5 x 17.6"

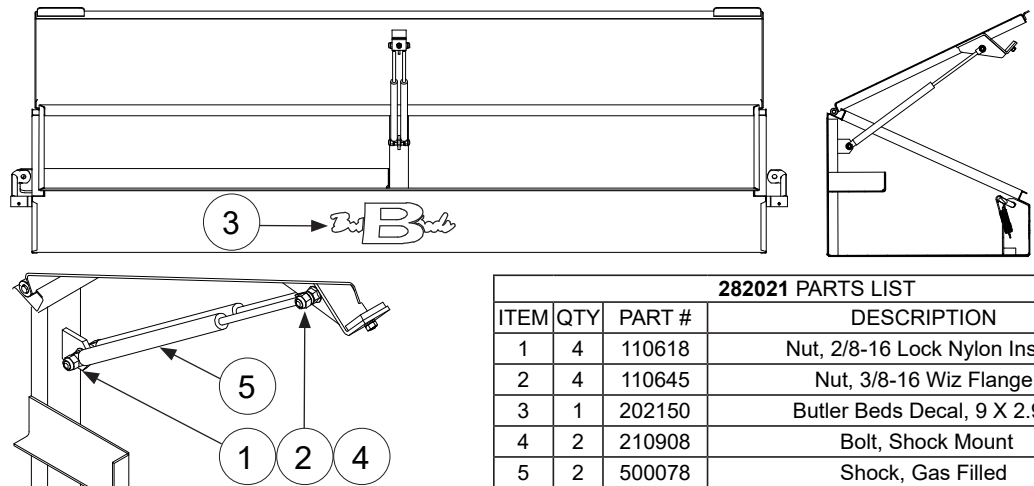

282021 PARTS LIST			
ITEM	QTY	PART #	DESCRIPTION
1	4	110618	Nut, 2/8-16 Lock Nylon Insert
2	4	110645	Nut, 3/8-16 Wiz Flange
3	1	202150	Butler Beds Decal, 9 X 2.97
4	2	210908	Bolt, Shock Mount
5	2	500078	Shock, Gas Filled

MUDFLAPS

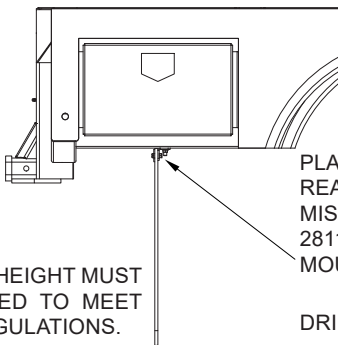
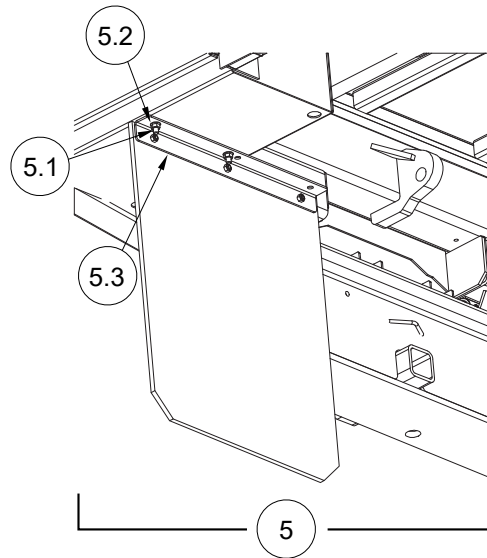
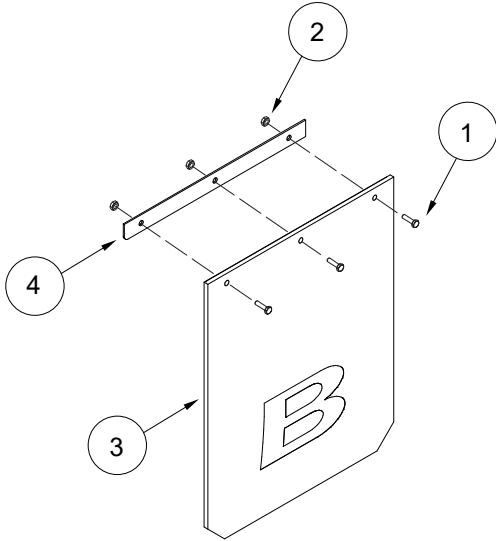

MUDFLAP HEIGHT MUST BE TRIMMED TO MEET LOCAL REGULATIONS.

PLACE MUDFLAP ON BOTTOM SIDE OF REAR BOX. PLACE APPROPRIATELY TO MISS EXHAUST SYSTEM. USE BRACKET 281125 AS A TEMPLATE FOR DRILLING MOUNTING HOLES.

DRILL HOLES $\varnothing 0.438$ (7/16 INCH)

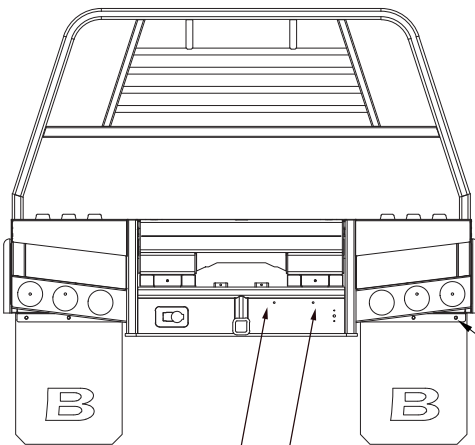

LICENSE PLATE HOLES ARE 3/8" NON-THREADED.

MOUNT MUDFLAP FLUSH WITH EDGE OF TOOLBOX

PARTS LIST

ITEM	QTY	PART #	DESCRIPTION
1	6	110423	Bolt, 5/16-18 X 1 Gr5 Zinc
2	6	110608	Nut, 5/16-18 Gr5 Zinc
3	2	202137	Mudflap, Butler, 24" (sold individually)
4	2	281265	Plate, Mudflap, 19 X 1.5, 3 Holes
5	1	205382	Kit, Mudflap Mount
5.1	4	110440	Bolt, 3/8-16 X 1, Wiz Flange
5.2	4	110645	Nut, 3/8-16 Wiz Flange
5.3	2	281125	Bracket, Mud Flap

BED MOUNTING KITS

PART#	DESCRIPTION	MAKE	TYPE	START	END
205162	Chevy General	GM	BD	1990	2010
205356	Chevy BD	GM	BD	2011	Current
205365	Chevy C&C	GM	C&C	1990	2010
205366	Chevy C&C	GM	C&C	2011	Current
205484	Chevy C&C, 45-6500 60" CA	GM	C&C	2019	Current
205485	Chevy C&C, 84" CA	GM	C&C	2011	Current
205490	Chevy C&C, 45-6500 84" CA	GM	C&C	2019	Current
205491	Chevy BD	GM	BD	2020	Current
205493	Chevy Short BD	GM	BD	2000	2010
205494	Chevy C&C, 84" CA	GM	C&C	2000	2010
205165	Dodge BD	Dodge	BD	1994	2002
205362	Dodge BD	Dodge	BD	2003	2013
205359	Dodge BD, 3500	Dodge	BD	2014	Current
205360	Dodge BD, 2500	Dodge	BD	2014	Current
205361	Dodge Short BD	Dodge	BD	2014	Current
205175	Dodge C&C	Dodge	C&C	2007	Current
205492	Dodge C&C, 84" CA	Dodge	C&C	2007	Current
205363	Ford Long Bed, BD	Ford	BD	1998	2016
205364	Ford Short Bed, BD	Ford	BD	1998	2016
205355	Ford BD	Ford	BD	2017	Current
205357	Ford C&C	Ford	C&C	1999	2016
205358	Ford C&C	Ford	C&C	2017	Current
205431	Add-on for 205358 with outboard DEF tank	Ford	C&C	2017	Current

REAR VIEW CAMERA MOUNTING KITS *

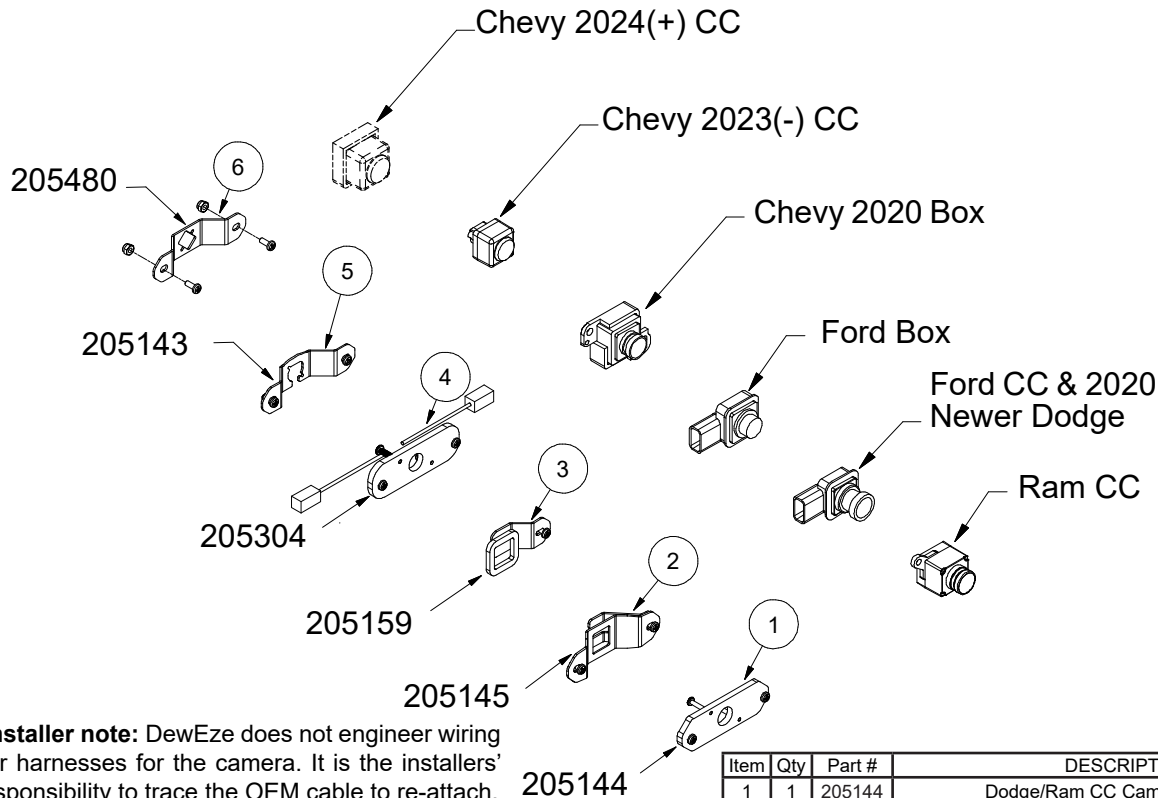

***Installer note:** DewEze does not engineer wiring nor harnesses for the camera. It is the installers' responsibility to trace the OEM cable to re-attach.

***Mount Disclaimer:** These mounting kits were designed for the most common mounting-to-camera. Manufacturers change camera styles & mountings even within the same year. Use best practices to modify if need be.

Item	Qty	Part #	DESCRIPTION
1	1	205144	Dodge/Ram CC Camera Mount Kit
2	1	205145	Ford Camera & Dodge 2020+ Mount Kit
3	1	205159	Ford Box Take-Off Camera Mount Kit
4	1	205304	Chevy/ GM 2020 Box Take-Off Camera Mount Kit
5	1	205143	Chevy/GM CC 2023- Camera Mount Kit
6	1	205480	Chevy/GM CC 2024+ Camera Mount Kit
7	1	261343	Camera Mount Weldment

BED LENGTHS FOR CAKE FEEDERS

(HEADACHE RACK TO GOOSENECK WELL)

Model Name	Type	Width	Length	Headache Rack to Front of Gooseneck Well Door
A84X84	arm	84	84	24
A84X101	arm	84	101	41
A84X108	arm	84	108	46.25
A84X113	arm	84	113	51.25
A90X108	arm	90	108	46.25
A90X113	arm	90	113	51.25
A90X137	arm	90	137	75.25
A94X84	arm	94	84	24
A94X101	arm	94	101	41
A94X108	arm	94	108	46.25
A94X113	arm	94	113	51.25
A94X132	arm	94	132	70.25
A94X137	arm	94	137	75.25
A96X84	arm	96	84	24
A96X101	arm	96	101	41
A96X108	arm	96	108	46.25
A96X113	arm	96	113	51.25
A96X132	arm	96	132	70.25
A96X137	arm	96	137	75.25
S80X86	spike	80	86	24
S80X102	spike	80	102	41
S80X110	spike	80	110	46.25
S80X115	spike	80	115	51.25
S84X86	spike	84	86	24
S84X102	spike	84	102	41
S84X110	spike	84	110	46.25
S84X115	spike	84	115	51.25
S90X110	spike	90	110	46.25
S90X115	spike	90	115	51.25
S90X139	spike	90	139	75.25
S94X86	spike	94	86	24
S94X102	spike	94	102	41
S94X110	spike	94	110	46.25
S94X115	spike	94	115	51.25
S94X134	spike	94	134	70.25
S94X139	spike	94	139	75.25
S96X86	spike	96	86	24
S96X102	spike	96	102	41
S96X110	spike	96	110	46.25
S96X115	spike	96	115	51.25
S96X134	spike	96	134	70.25
S96X139	spike	96	139	75.25
R80X86	regular	80	86	24
R80X102	regular	80	102	41
R80X110	regular	80	110	46.25
R80X115	regular	80	115	51.25
R84X86	regular	84	86	24
R84X102	regular	84	102	41
R84X110	regular	84	110	46.25
R84X115	regular	84	115	51.25
R90X110	regular	90	110	46.25
R90X115	regular	90	115	51.25
R90X139	regular	90	139	75.25
R94X86	regular	94	86	24
R94X102	regular	94	102	41
R94X110	regular	94	110	46.25
R94X115	regular	94	115	51.25
R94X134	regular	94	134	70.25
R94X139	regular	94	139	75.25
R96X86	regular	96	86	24
R96X102	regular	96	102	41
R96X110	regular	96	110	46.25
R96X115	regular	96	115	51.25
R96X134	regular	96	134	70.25
R96X139	regular	96	139	75.25

NOTES

Harper Industries, Inc.
151 E. Highway 160
Harper, KS 67058

Telephone: 620-896-7381
Toll-Free: 800-835-1042
Fax: 620-896-7129

Website: www.butlerbeds.com

E-mail: info@butlerbeds.com